

PURPOSE:

The purpose of this EDOC is to specify the parts required for changing the travel speed on 1-5 Ton MR & 1-3 Ton SMR trolleys and to provide step by step instructions and illustrations for shop, distributors and repair centers. This process pertains to all speed changes on 1-5 ton MR trolleys and speed changes on 1-3 Ton SMR trolleys model MP1B. Available speeds are 40 F.P.M. (feet per minute) and 80 F.P.M.

****IMPORTANT**** - Model MP1A SMR trolleys are only available at 40 F.P.M.

PARTS REQUIRED:

1. Replacement gearbox packing, part # MR1DS9248
2. Replacement gear #2 (select desired speed)
 - a. 40 F.P.M. (L), part # MR1DL9241 -Low Speed
 - b. 80 F.P.M. (S), part # MR1DS9241 -Standard Speed

INSTRUCTIONS:

1. Remove the motor frame assembly from side plate "G" assembly by removing the 4 socket head bolts.

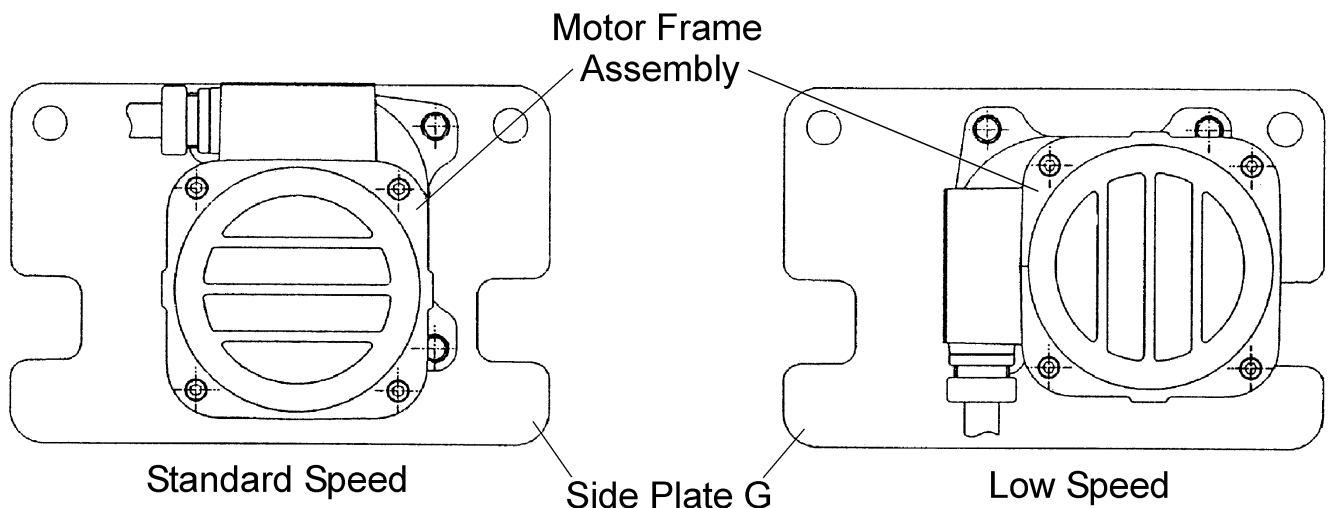

2. Remove the two set pins (item #47) from side plate “G” assembly and reinsert into the motor frame assembly.
3. Remove the gearbox packing and discard. (item #46)

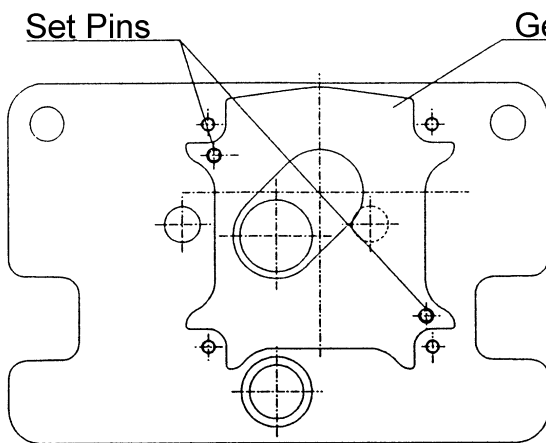

Standard Speed

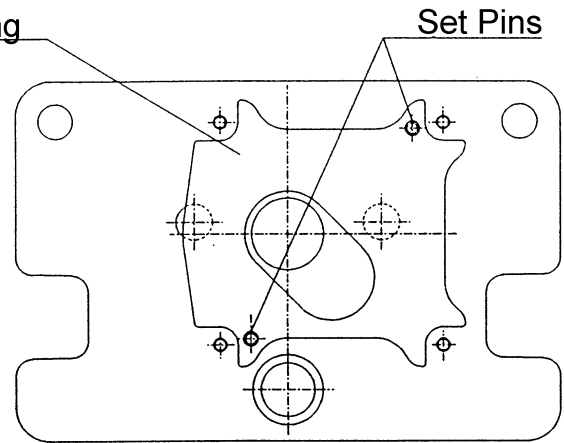

Low Speed

4. Remove the gear assembly (items # 39 through # 45) from the motor frame gearbox.

Complete Gear Set
(For Standard Speed)

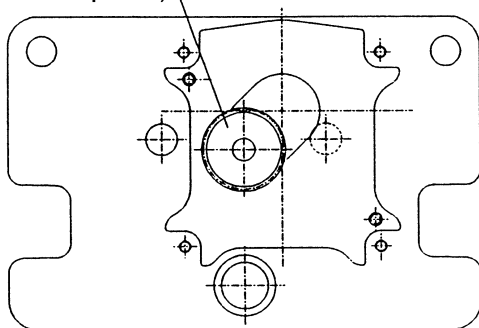

Standard Speed

Complete gear set
(For Low speed)

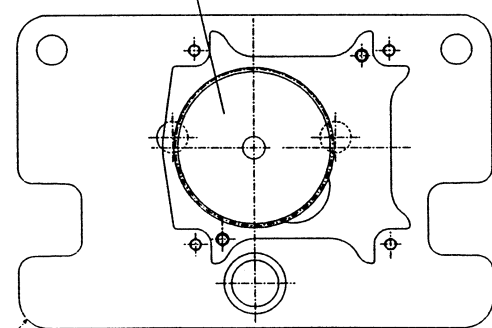

Low Speed

Side Plate G

5. Remove the snap ring (item # 39) from the gear assembly.
6. Remove gear #2 (item # 40) from the gear assembly and install the replacement gear.
7. Reinstall snap ring (item # 39) back onto gear assembly.
8. Reinsert the gear assembly back onto the gearbox.

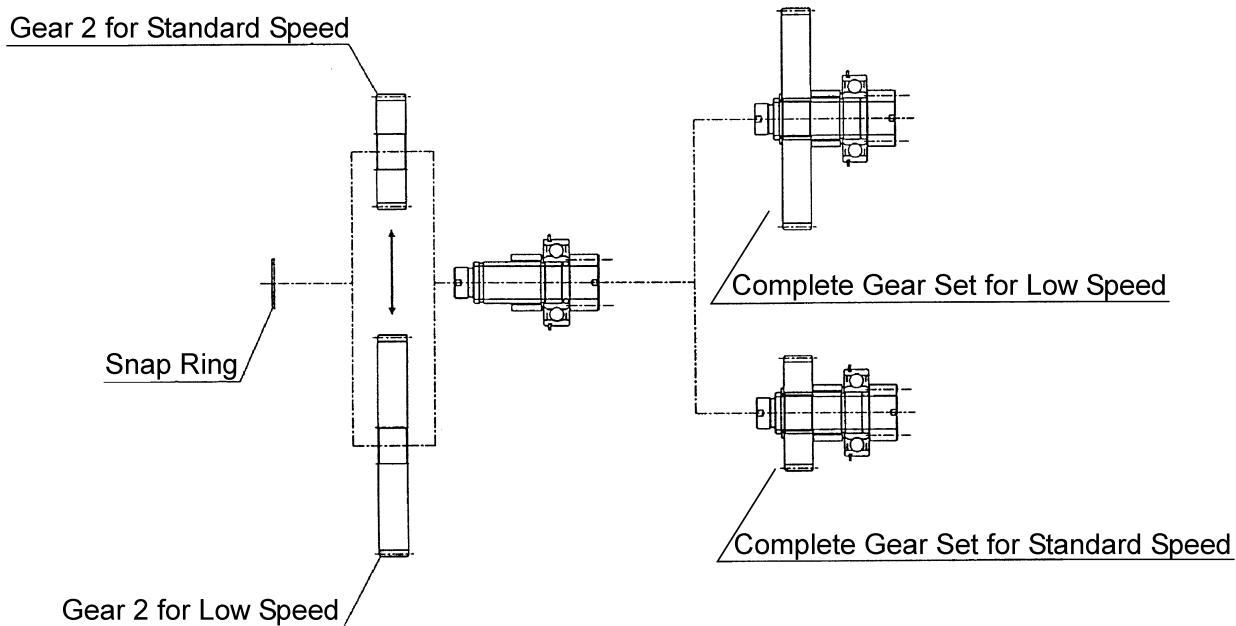

9. Reinstall the new gearbox packing (item # 46)
10. Rotate the motor frame assembly 90° from its original orientation (see below).

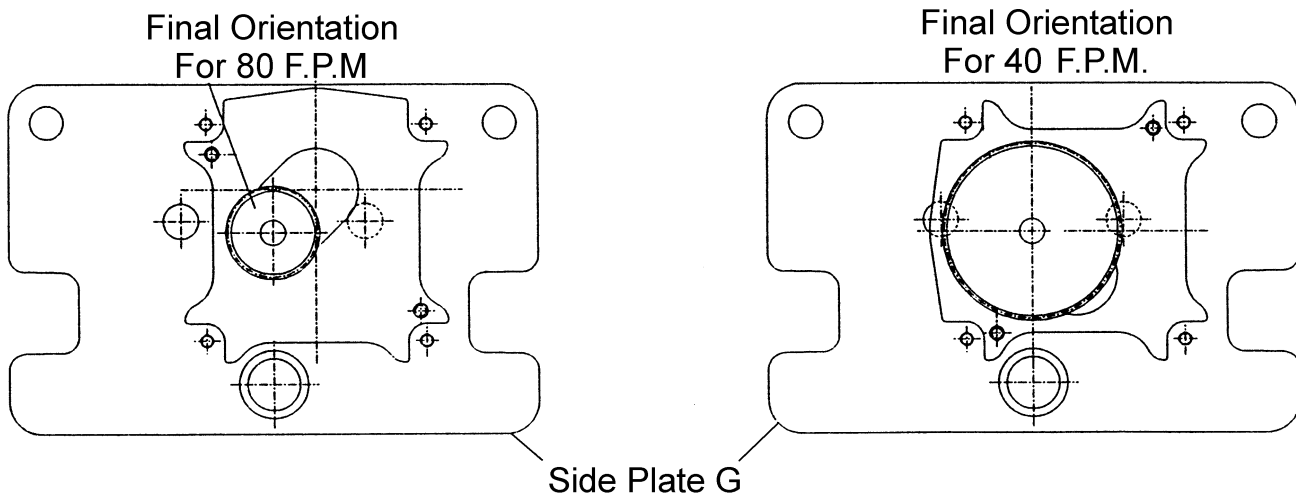

11. Reinstall the motor frame assembly back onto side plate "G" assembly, making sure that the two set pins (item #47) are on the motor frame and properly aligned with the holes on side plate "G".
12. Reinstall the 4 socket head bolts and tighten to 10ft*lbs.