

Heavy Duty Class C Single Girder Series 3 Underhung Complete Cranes

Harrington Underhung cranes combine superior performance with underhung space savings. It's a rugged design that easily handles today's most demanding Class "C" applications, including fabricating, machining, die handling, production, assembly and maintenance. All bolted assembly makes installation quick and easy—no welding required. Most wiring connections are factory installed or plug-in type. You can rely on Harrington cranes for durability, reliability and years of trouble-free service. Count on Harrington to include standard features that are options on competitors' cranes.



All bolted construction
for ease in assembly

Field adjustable Electronic Acceleration Control (EAC)
for superior load control (see page 28)

Side guide rollers
on motorized trolleys
for smooth movement

Electric hoists feature 60 minute rating,
fan cooled motor
and "The Guardian"
smart brake technology

Quick disconnect cords
for ease of installation
and maintenance

Forged carbon-steel hook
capable of swiveling 360° under load

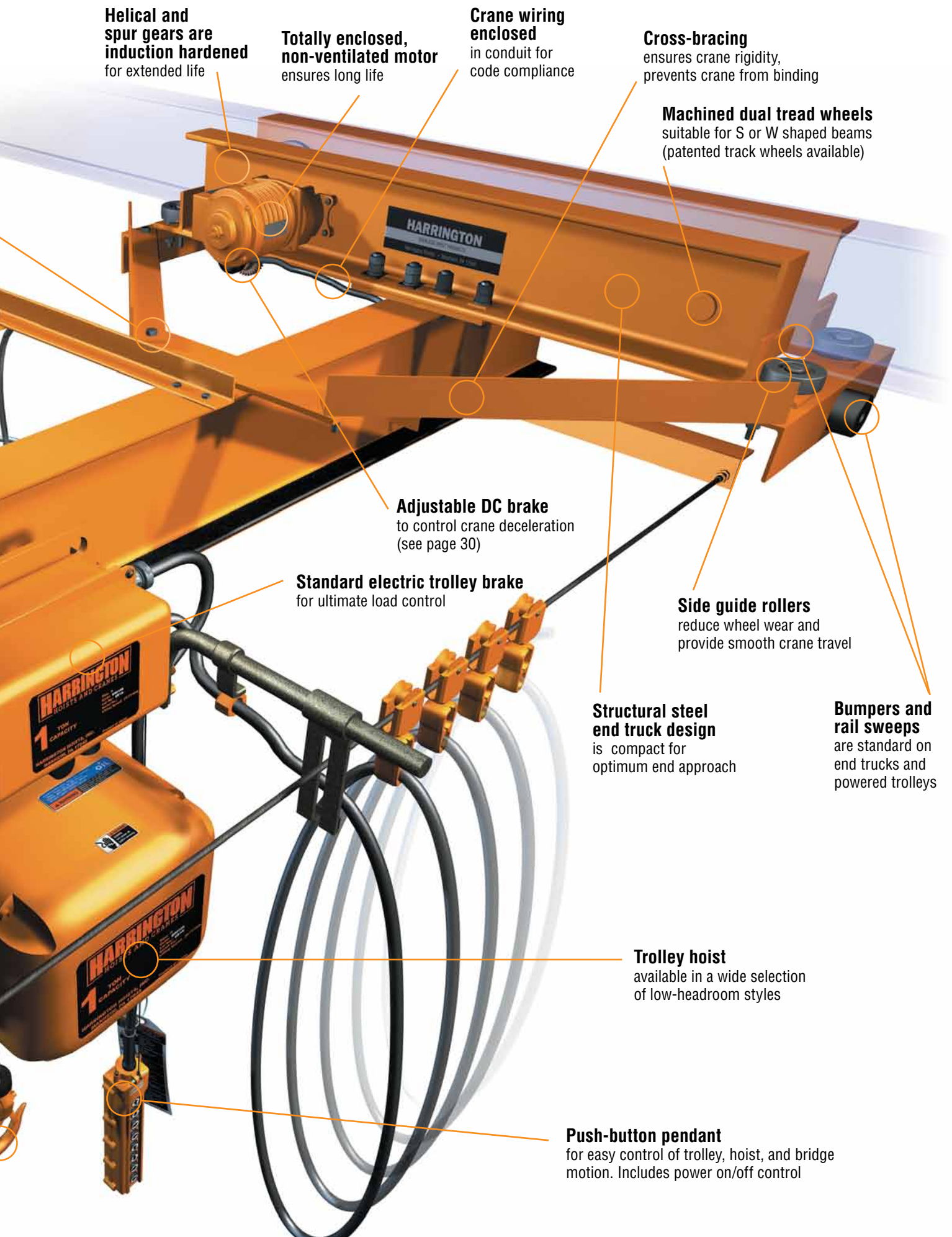

Helical and spur gears are induction hardened for extended life

Totally enclosed, non-ventilated motor ensures long life

Crane wiring enclosed in conduit for code compliance

Cross-bracing ensures crane rigidity, prevents crane from binding

Machined dual tread wheels suitable for S or W shaped beams (patented track wheels available)

Adjustable DC brake to control crane deceleration (see page 30)

Standard electric trolley brake for ultimate load control

Side guide rollers reduce wheel wear and provide smooth crane travel

Structural steel end truck design is compact for optimum end approach

Bumpers and rail sweeps are standard on end trucks and powered trolleys

Trolley hoist available in a wide selection of low-headroom styles

Push-button pendant for easy control of trolley, hoist, and bridge motion. Includes power on/off control

Heavy Duty Class C Single Girder Series 3 Underhung Motorized Complete Cranes

Many benefits from more features:

- Adjustable Electronic Acceleration Control (EAC) and adjustable brake allow customized speed control to avoid load swing and optimize load control.
- Standard rubber bumpers on cranes and motorized trolleys comply with ASME requirements.
- Side guide rollers reduce wheel friction and noise, providing smooth crane travel and increased wheel and runway life.
- Stationary crane wires are enclosed in conduit to comply with NEC requirements.
- Thermal motor protection is standard to protect motor from overheating.
- Electric hoists with ASME H4 rating maximize lifting capability while minimizing downtime and expense.
- Sealed motors enhance motor life and minimize repair costs.
- Drives deliver synchronous power to two wheels on each end truck for smooth positive traction. (See page 31)

Capabilities to count on:

- Capacities through 5 Ton and spans through 50 feet.
- Crane speeds: 40, 80, 120 ft/min single speed, 80/20 ft/min dual speed, or variable speed.
- Motorized trolley speeds: 40 or 80 ft/min single speed, 80/20 ft/min dual speed or variable speed. Also available with manual trolley (geared or push).
- 3 phase voltages: 208, 230/460, 380, 575 (50 or 60 Hz).
- Suitable for use on S or W shaped beam (patented track models available).

Complete crane system includes:

- End trucks come standard with drives, brakes, bumpers, drop stops, and rail sweeps.
- Crane control panel with adjustable Electronic Acceleration Control (EAC) and thru-the-door lock-out disconnect switch. (See page 28.)
- Crane wiring installed in code-compliant conduit.
- Standard bridge beam assembly with bracing and capacity labels.
- Trolley hoist supplied with operator control pendant.
- Optional runway electrification.
- Documentation including assembly and installation instructions, crane operator's guide, and owner's manuals.
- Touch-up paint.
- One year warranty.

SERIES 3 UNDERHUNG MOTORIZED SINGLE GIRDER COMPLETE CRANES — DIMENSIONS

Cap. (Tons)	Max Span (ft)	Crane Product Code	Wheel Dia. (in)	T Flange Range Std. (in)	A Overall Length (in)	B Roller Base (in)	D Wheel Base (in)	E* Beam Beyond Span (in)	M End Truck Frame Width (in)	U Wheel Running Surface to Top of Beam (in)	X** Width Beyond Span (in)	Y Wheel Running Surface to Upper Most Part of Crane (in)	G Motor (in)
2	35	CUML/S/H/D-3-0235	4.33	3 - 6	60	53	39	12	T+8.1	1.8	11.3-T/2	6.5	T/2+ 11.9 (L/S) 12.3 (H) 13.3 (D)
	50	CUML/S/H/D-3-0250			82	75	61		T+8.2				
3	35	CUML/S/H/D-3-0335	4.92		60	53	35		T+8.2	1.9			
	50	CUML/S/H/D-3-0350			82	75	57		T+9.8				
5	35	CUML/S/H/D-3-0535	5.51	4 - 6	60	53	33	T+9.8	2.0	6.8	T/2+ 13.7 (L/S/D) 14.2 (H)		
	50	CUML/S/H/D-3-0550			82	75	55						

* Minimum E is M/2.

**These formulas for Width Beyond Span do not apply for flanges greater than 6 inches. For flanges greater than 6 inches, consult factory.

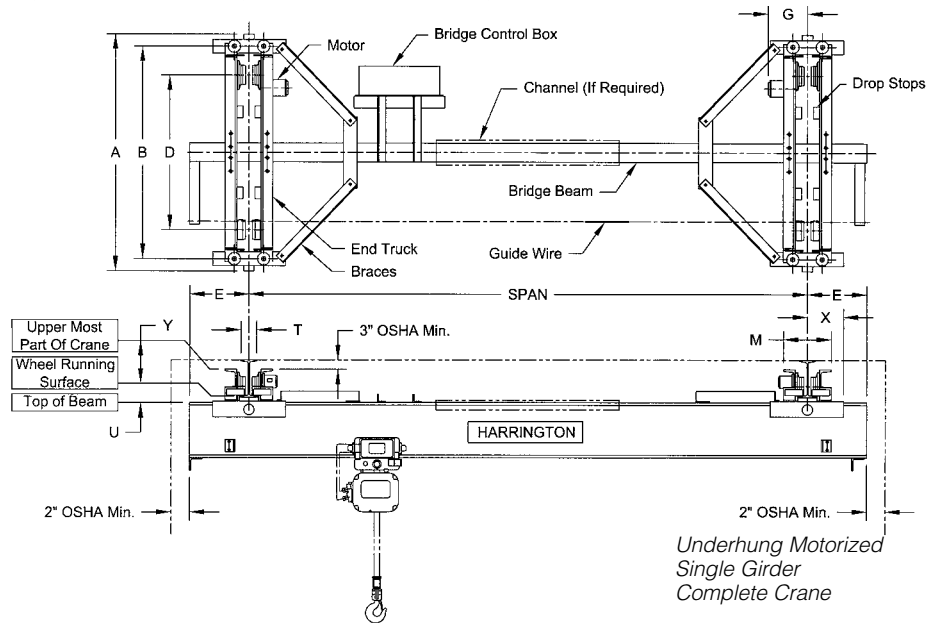

Underhung Motorized Single Girder Complete Crane

SERIES 3 UNDERHUNG MOTORIZED SINGLE GIRDER COMPLETE CRANES — SPECIFICATIONS

Crane Product Code	Speed Codes L and S			Speed Code H			Speed Code D			System Max. Wheel Load* (lbs/wheel pair)
	One Motor Per End Truck 3 Phase 60 Hz			One Motor Per End Truck 3 Phase 60 Hz			One Motor Per End Truck 3 Phase 60 Hz			
	Output (Hp)	Rated Current (amps ea.)		Output (Hp)	Rated Current (amps ea.)		Output (Hp)	Rated Current (amps ea.)		
	@230V	@460V		@230V	@460V		@230V	@460V		
CUML/S/H/D-3-0235	0.33	1.6	1.0	0.5	2.1	1.3	0.33/0.08	1.6/1.1	0.9/0.8	3,170
CUML/S/H/D-3-0250										3,930
CUML/S/H/D-3-0335										4,480
CUML/S/H/D-3-0350										5,170
CUML/S/H/D-3-0535	0.5	2.1	1.3	1.0	3.3	2.0	0.5/0.13	2.0/1.5	1.2/0.9	6,960
CUML/S/H/D-3-0550										7,670

*See definition on page 26.

Speed Code

- L - Designates 40 ft/min
- S - Designates 80 ft/min
- H - Designates 120 ft/min
- D - Designates dual speed 80/20 ft/min

Product Code Derivation - example: CUML-3-0235

- CU - Complete Underhung Crane
- M - Motorized
- L - Speed of 40 ft/min
- 3 - Series number
- 02 - Max. capacity - 2 Ton
- 35 - Maximum span - 35 feet

Heavy Duty Class C Single Girder Series 3 Underhung Geared Complete Cranes

Harrington's underhung geared cranes offer an economical alternative to motorized systems. Side guide rollers mean these systems operate much easier than flanged wheel cranes. Consider geared operation where precision control is required, such as die handling or fabrication assembly operations. Geared cranes are easily upgradable to motorized systems to meet changing customer needs.

Many benefits from more features:

- Ideal for precision spotting requirements where motorized operation is not necessary.
- Standard rubber bumpers on cranes and motorized trolleys comply with ASME requirements.
- Side guide rollers reduce wheel friction and noise, providing smooth crane travel and increased wheel and runway life.
- Electric hoists with ASME H4 rating maximize lifting capability while minimizing downtime and expense.
- Sealed hoist and trolley motors enhance motor life and minimize repair costs.

Capabilities to count on:

- Capacities through 5 Ton and spans through 45 feet.
- Motorized trolley speeds: 40 or 80 ft/min single speed, 80/20 ft/min dual speed or variable speed. Manual trolleys also available (push or hand geared).
- Suitable for use on S or W shaped beam (patented track models available).

Complete crane system includes:

- End trucks come standard with bumpers, drop stops, and rail sweeps.
- Drive shaft assembly with hand wheel and hand chain.
- Standard bridge beam assembly with bracing and capacity labels.
- Trolley hoist available in a wide selection of styles.
- Power supply to trolley hoist (if required).
- Optional runway electrification.
- Documentation, including assembly and installation instructions, crane operator's guide, and owner's manuals.
- Touch-up paint.
- One year warranty.

SERIES 3 UNDERHUNG GEARED SINGLE GIRDER COMPLETE CRANES — SPECIFICATIONS & DIMENSIONS

Cap. (Tons)	Max Span (ft)	Crane Product Code	Wheel Dia. (in)	T Flange Range Std. (in)	A Overall Length (in)	B Roller Base (in)	D Wheel Base (in)	E* Beam Beyond Span (in)	J Hand Wheel Offset (in)	M End Truck Frame Width (in)	U Wheel Running Surface to Top of Beam (in)	X** Width Beyond Span (in)	Y Wheel Running Surface to Upper Most Part of Crane (in)	System Max. Wheel Load† (lbs per wheel pair)
2	35	CUG-3-0235	4.33	3 - 6	60	53	39	12	T/2+9.0	T+8.1	1.8	11.3-T/2	6.5	3,160
	45	CUG-3-0245			82	75	61							3,620
3	35	CUG-3-0335	4.92		60	53	35		T/2+8.9	T+8.2	1.9		6.7	4,480
	45	CUG-3-0345			82	75	57							4,990
5	35	CUG-3-0535	5.51	4 - 6	60	53	33	T/2+9.0	T+9.8	2.0	6.8	6,950		
	45	CUG-3-0545			82	75	55					7,400		

*Minimum E is M/2.

**These formulas for Width Beyond Span do not apply for flanges greater than 6 inches. For flanges greater than 6 inches, consult factory.

***Standard hand chain drop is 8 ft from bottom of running beam.

† See definition on page 26.

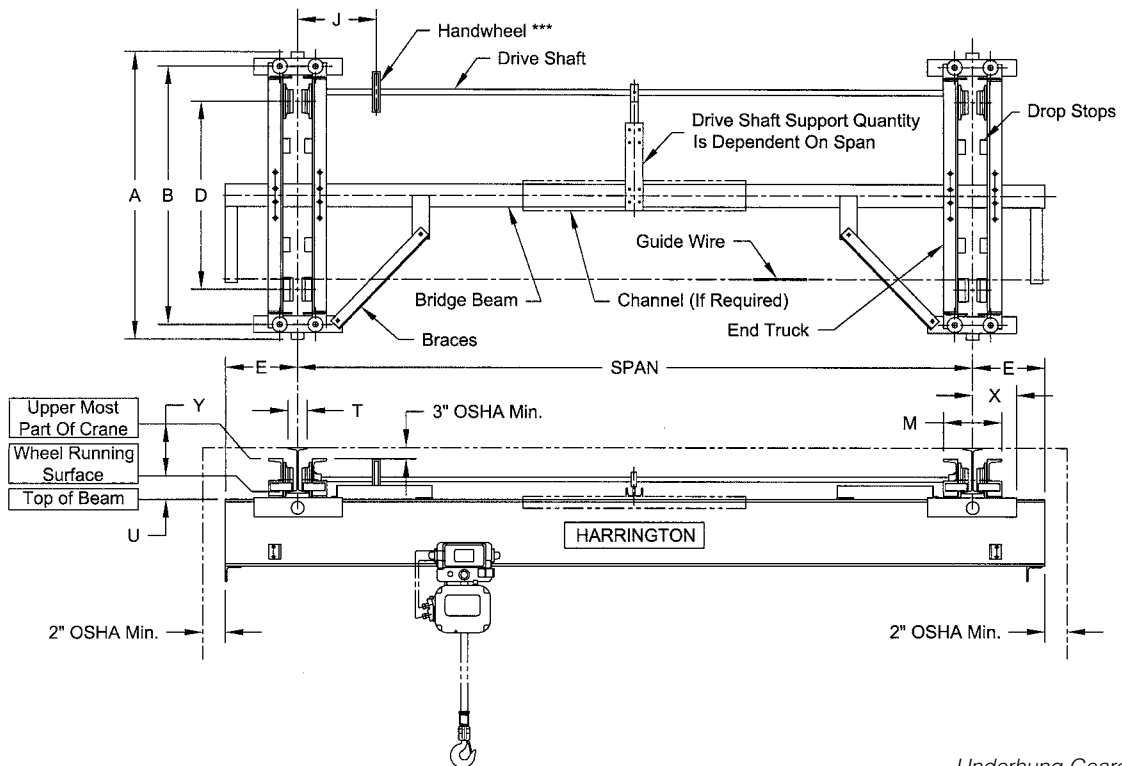

Underhung Geared Single Girder Complete Crane

Heavy Duty Class C Single Girder Series 3 Underhung Push Complete Cranes

Harrington's underhung push cranes offer an economical alternative to other cranes. Side guide rollers mean these systems operate much easier than flanged wheel cranes. Push cranes are easily upgradable to motorized or geared operation to meet changing customer needs.

Many benefits from more features:

- Compared to flanged wheel cranes, Harrington's push cranes operate easily, particularly in long span operations.
- Standard rubber bumpers on cranes and motorized trolleys comply with ASME requirements.
- Side guide rollers reduce wheel friction and noise, providing smooth crane travel and increased wheel and runway life.
- Electric hoists with ASME H4 rating maximize lifting capability while minimizing downtime and expense.
- Sealed hoist and trolley motors enhance motor life and minimize repair costs.

Capabilities to count on:

- Capacities through 5 Ton and spans through 45 feet.
- Motorized trolley speeds: 40 or 80 ft/min single speed, 80/20 ft/min dual speed or variable speed. Manual trolleys also available (push or geared).
- Suitable for use on S or W shaped beam (patented track models available).

Complete crane system includes:

- End trucks come standard with bumpers, drop stops, and rail sweeps.
- Standard bridge beam assembly with bracing and capacity labels.
- Trolley hoist available in a wide selection of styles.
- Power supply to trolley hoist (if required).
- Optional runway electrification.
- Documentation including assembly and installation instructions, crane operator's guide, and owner's manuals.
- Touch-up paint.
- One year warranty.

SERIES 3 UNDERHUNG PUSH SINGLE GIRDER COMPLETE CRANES — SPECIFICATIONS & DIMENSIONS

Cap. (Tons)	Max Span (ft)	Crane Product Code	Wheel Dia. (in)	T Flange Range Std. (in)	A Overall Length (in)	B Roller Base (in)	D Wheel Base (in)	E* Beam Beyond Span (in)	M End Truck Frame Width (in)	U Wheel Running Surface to Top of Beam (in)	X** Width Beyond Span (in)	Y Wheel Running Surface to Upper Most Part of Crane (in)	System Max. Wheel Load*** (lbs/wheel pair)
2	35	CUP-3-0235	4.33	3 - 6	60	53	39	12	T+8.1	1.8	11.3-T/2	6.5	3,150
	45	CUP-3-0245			82	75	61		T+8.2	1.9			3,580
3	35	CUP-3-0335	4.92	60	53	35	T+8.2		1.9	4,440			
5	35	CUP-3-0535	5.51	4 - 6	60	53	33		T+9.8	2.0			6,910

*Minimum E is M/2.
 **These formulas for Width Beyond Span do not apply for flanges greater than 6 inches. For flanges greater than 6 inches, consult factory.
 ***See definition on page 26.

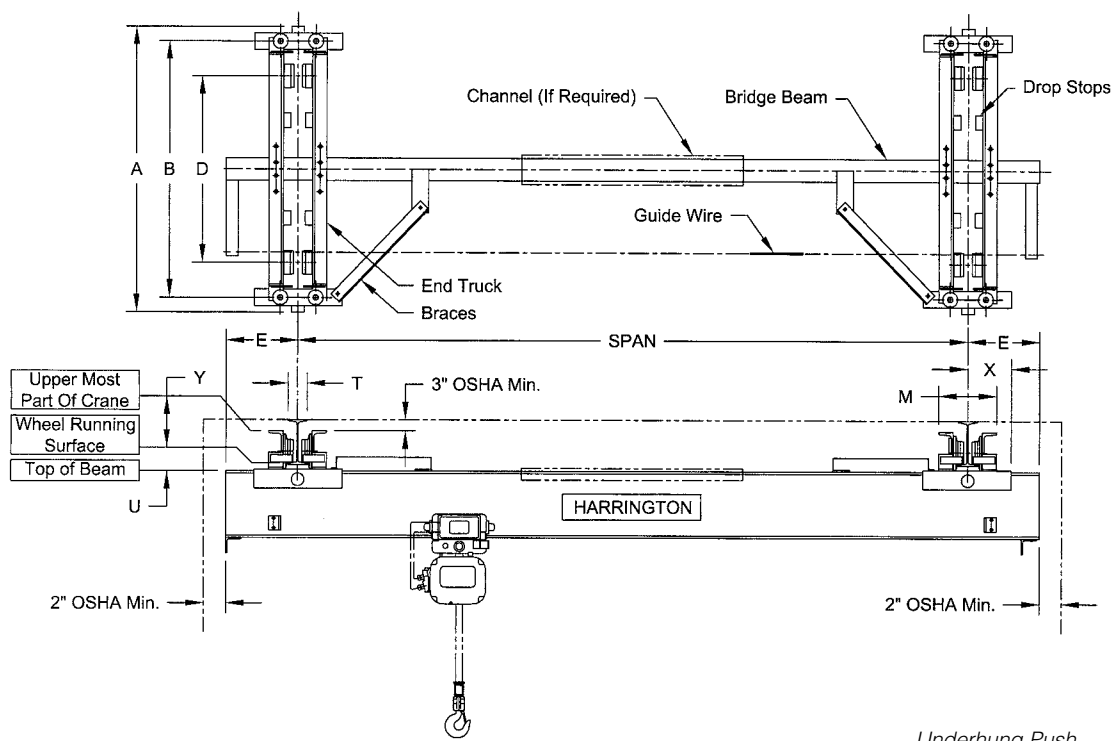

Underhung Push Single Girder Complete Crane