

## MTM—Double Girder Max-E-Lift Top Running Motorized End Trucks

For a compact, double girder configuration with all the benefits of the TM top running motorized single girder design, go with Harrington MTM end trucks. Along with a full range of features, end truck kits include: two trucks; two sealed, totally enclosed non-ventilated (TENV) motors with adjustable D.C. brakes; two helical gear reducers; rubber bumpers; and bridge beam fastener set. All trucks are fully painted. Bridge fabrication prints are also included. As a member of Crane Manufacturers Association of America (CMAA), Harrington builds MTM trucks to meet current industry and regulatory codes.

### Benefits to count on:

- Frame fabricated from ASTM A500 structural tube for superior strength, rigidity, and compactness.
- Crane end approach is significantly better than competitive models.
- Standard 36" gauge for 5 Ton and down, 48" on 10 Ton model—other gauges available.
- Purchase the right component for the job—dedicated models for capacities of 1, 3, 5 and 10 Ton with maximum span increments of 35' or 60'.
- Minimize assembly labor with fully machined frames—girder connection and collector mounting bracket holes are drilled and tapped for easy crane assembly.
- Ideal when new head room requirements in an existing application necessitate a new crane, or when head room allows lower building heights for new construction.
- Integrates with most top running, double girder trolley hoists.
- Use with the low profile Harrington Max-E-Lift trolley hoist for the ultimate low-crane profile.
- Sealed TENV drives with quiet, smooth-operating helical gear reducers.
- Gear reducer is designed for easy field conversion between L and S speeds.
- Drives are designed for crane service, with 30 minute rating and feature cooling fins for efficient heat dissipation.
- Externally adjustable D.C. brakes allow controlled deceleration—adjustable up to 50% of rated motor torque.
- Thermal motor protection is standard.
- Drives and brakes are compatible with Electronic Acceleration Control (EAC) and Variable Frequency Drive (VFD).
- Drives are connectable for 230/460V-3-60 (including dual speed models). Other voltages available.
- Rail sweeps and drop stops are standard.
- Longer or shorter end truck lengths are available—consult factory.

**Also available in geared models.  
Consult factory for specs.**

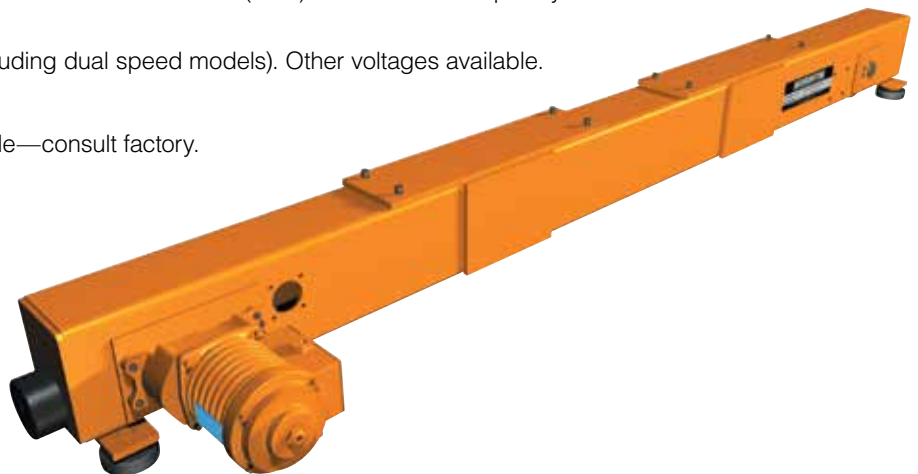

**MTM — MAX-E-LIFT TOP RUNNING MOTORIZED END TRUCK — DIMENSIONS**

Cap. (Tons)	Max. Span (ft)	End Truck Product Code	Wheel Dia. (in)	Sug. Min. Runway Rail (ASCE#)	A Overall Length (in)	B Roller Base (in)	D Wheel Base (in)	K Beam Gauge (in)	N Runway Ctr. Line to Outer Edge of ET Tube (in)	X* Width Beyond Span (in)	Y Top of Rail to Top of End Truck (in)	G Motor (in)		
1	35	MTML/S/H/D-3-0135	3.74	30	72	64	54	36	2.1	4.6	7.1	12.7 (L/S)		
	60	MTML/S/H/D-3-0160			111	103	93		13.1 (H)					
3	35	MTML/S/H/D-3-0335	6.10		75	67	56		3.8			4.7	9.2	13.0 (L/S)
	60	MTML/S/H/D-3-0360			112	104	93							13.4 (H)
5	35	MTML/S/H/D-3-0535	8.27	40	75	67	56	3.5	4.7	9.3	15.0 (L/S/D)			
	60	MTML/S/H/D-3-0560			112	103	87				15.4 (H)			
10	35	MTML/S/H/D-3-1035	9.84	60	93	83	67	48	5.3	6.3	11.3	17.4 (L/S/D)		
	60	MTML/S/H/D-3-1060			113	103	87					18.7 (H)		

\*Based on suggested minimum runway rail.

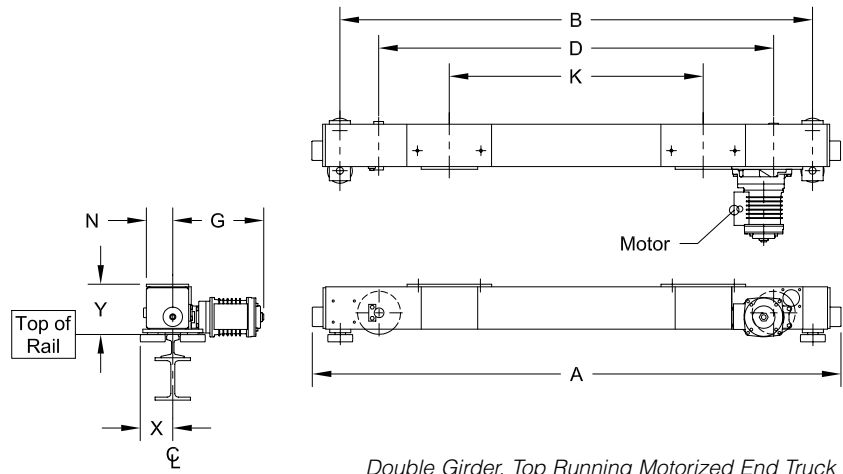

Double Girder, Top Running Motorized End Truck

**MTM — MAX-E-LIFT TOP RUNNING MOTORIZED END TRUCK — SPECIFICATIONS**

End Truck Product Code	Speed Codes L and S			Speed Code H			Speed Code D			End Truck Weight (lbs/pr)
	One Motor Per End Truck 3 Phase 60 Hz			One Motor Per End Truck 3 Phase 60 Hz			One Motor Per End Truck 3 Phase 60 Hz			
	Output (Hp)	Rated Current (amps ea.)		Output (Hp)	Rated Current (amps ea.)		Output (Hp)	Rated Current (amps ea.)		
		@230V	@460V		@230V	@460V		@230V	@460V	
MTML/S/H/D-3-0135	0.33	1.6	1.0	0.5	2.1	1.3	0.33/0.08	1.6/1.1	0.9/0.8	340
MTML/S/H/D-3-0160										441
MTML/S/H/D-3-0335										526
MTML/S/H/D-3-0360										647
MTML/S/H/D-3-0535										648
MTML/S/H/D-3-0560	0.5	2.1	1.3	1.0	3.3	2.0	0.5/0.13	2.0/1.5	1.2/0.9	818
MTML/S/H/D-3-1035	1.0	3.3	2.0	2.0	5.8	3.1	1.0/0.25	3.7/2.1	2.3/1.4	1,105
MTML/S/H/D-3-1060										1,202

**Speed Code**

- L - Designates 40 ft/min
- S - Designates 80 ft/min
- H - Designates 120 ft/min
- D - Designates dual speed 80/20 ft/min

**Product Code Derivation - example: MTML-3-0135**

- 1st M - Max-E-Lift Style
- T - Top Running
- 2nd M - Motorized
- L - Speed of 40 ft/min
- 3 - Series Number
- 01 - Max. Capacity - 1 Ton
- 35 - Maximum Span - 35 feet

## **MUM—Double Girder Max-E-Lift Underhung Motorized End Trucks**

Harrington MUM end trucks offer the same benefits of the UM underhung motorized single girder series, but in a compact, double girder configuration. Unique for double girder cranes, these end trucks offer the dimensional advantage of an underhung crane combined with a top running trolley. Along with many important features, end truck kits include: two end trucks; two sealed, totally enclosed, non-ventilated (TENV) motors with adjustable electric brakes; two helical gear reducers; rubber bumpers; and bridge beam fastener set. All trucks are fully painted. Bridge fabrication prints are also included. As a member of Crane Manufacturers Association of America (CMAA), Harrington builds MUM trucks to meet current industry and regulatory codes.

### **Benefits to count on:**

- Unique design combining double girder underhung crane with top running trolley hoist increases high hook and minimizes crane profile.
- Purchase the right component for the job—dedicated models for capacities of 2, 3, and 5 Ton, with maximum span increments of 35' or 50'.
- Offers significantly better crane end approach than most double girder cranes.
- Minimize assembly labor with fully machined frames—girder connection and collector mounting bracket holes are pre-drilled for easy crane assembly.
- Standard 36" gauge—other gauges available.
- Integrates with most top running, double girder trolley hoists.
- Specially designed to accept the Harrington Max-E-Lift low profile trolley hoist.
- Sealed TENV drives with quiet, smooth-operating helical gear reducers.
- Gear reducer is designed for easy field conversion between L and S speeds.
- Drives are designed for crane service, with 30 minute rating and feature cooling fins for efficient heat dissipation.
- Externally adjustable D.C. brakes allow controlled deceleration—adjustable up to 50% of rated motor torque.
- Thermal motor protection is standard.
- Drives and brakes are compatible with Electronic Acceleration Control (EAC) and Variable Frequency Drive (VFD).
- Drives are connectable for 230/460V-3-60 (including dual speed models). Other voltages available.
- Rail sweeps and drop stops are standard.
- Longer or shorter end truck lengths are available—consult factory.

**Also available in geared models.  
Consult factory for specs.**



**MUM — MAX-E-LIFT UNDERHUNG MOTORIZED END TRUCK — DIMENSIONS**

Cap. (Tons)	Max. Span (ft)	End Truck Product Code	Wheel Dia. (in)	T Flange Range Std. (in)	A Overall Length (in)	B Roller Base (in)	D Wheel Base (in)	M End Truck Frame Width (in)	N Runway Ctr. Line to Outer Edge of ET (in)	R Wheel Running Surf. to Bottom of Truck (in)	X* Width Beyond Span (in)	Y Wheel Running Surface to Upper Most Part of ET (in)	G Motor (in)	
2	35	MUML/S/H/D-3-0235	4.33	3 - 6	87	80	66	T+8.1	M/2	1.5	11.3 - T/2	6.5	T/2+ 11.9 (L/S) 12.3 (H) 13.3 (D)	
	50	MUML/S/H/D-3-0250			99	92	78							
3	35	MUML/S/H/D-3-0335	4.92		91	84	66	T+8.2						1.6
	50	MUML/S/H/D-3-0350			103	96	78							
5	35	MUML/S/H/D-3-0535	5.51		4 - 6	95	88	68		T+9.8				
	50	MUML/S/H/D-3-0550				107	100	80						

\*These formulas for Width Beyond Span do not apply for flanges greater than 6 inches. For flanges greater than 6 inches, consult factory.

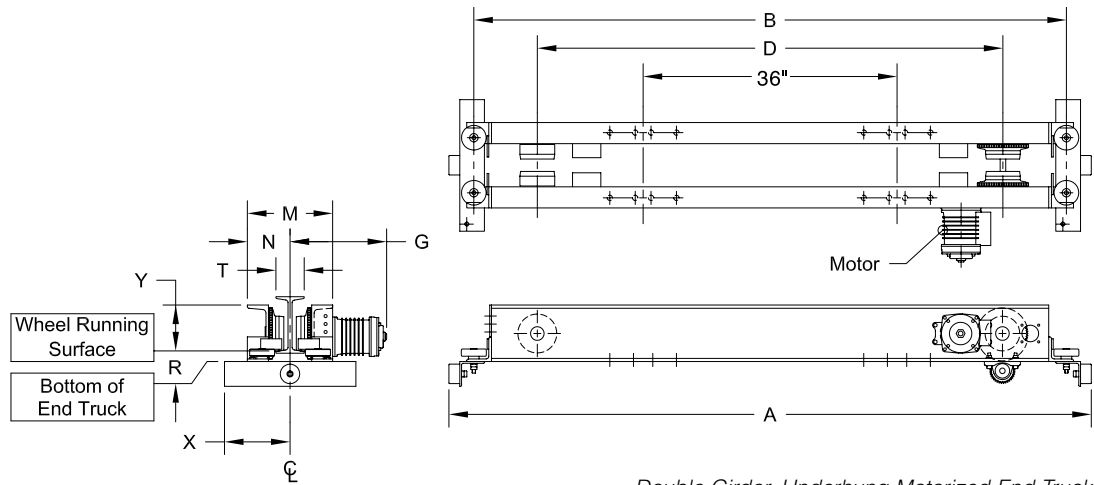

Double Girder, Underhung Motorized End Truck

**MUM — MAX-E-LIFT UNDERHUNG MOTORIZED END TRUCK — SPECIFICATIONS**

End Truck Product Code	Speed Codes L and S			Speed Code H			Speed Code D			End Truck Weight (lbs/pr)
	One Motor Per End Truck 3 Phase 60 Hz			One Motor Per End Truck 3 Phase 60 Hz			One Motor Per End Truck 3 Phase 60 Hz			
	Output (Hp)	Rated Current (amps ea.)		Output (Hp)	Rated Current (amps ea.)		Output (Hp)	Rated Current (amps ea.)		
		@230V	@460V		@230V	@460V		@230V	@460V	
MUML/S/H/D-3-0235	0.33	1.6	1.0	0.5	2.1	1.3	0.33/0.08	1.6/1.1	0.9/0.8	690
MUML/S/H/D-3-0250										765
MUML/S/H/D-3-0335										736
MUML/S/H/D-3-0350										811
MUML/S/H/D-3-0535	0.5	2.1	1.3	1.0	3.3	2.0	0.5/0.13	2.0/1.5	1.2/0.9	888
MUML/S/H/D-3-0550										973

**Speed Code**

- L - Designates 40 ft/min
- S - Designates 80 ft/min
- H - Designates 120 ft/min
- D - Designates dual speed 80/20 ft/min

**Product Code Derivation - example: MUML-3-0235**

- 1st M - Max-E-Lift Style
- U - Underhung
- 2nd M - Motorized
- L - Speed of 40 ft/min
- 3 - Series Number
- 02 - Max. Capacity - 2 Ton
- 35 - Maximum Span - 35 feet