

---

# OWNER'S MANUAL SUPPLEMENT

---

## **ELECTRIC CHAIN HOIST ED SERIES ED1050**

1050 Lb. Capacity

Code, Lot and Serial Number

### **⚠ WARNING**

This equipment should not be installed, operated or maintained by any person who has not read and understood all the contents of this manual. Failure to read and comply with the contents of this manual can result in serious bodily injury or death, and/or property damage.

**HARRINGTON**  
A KITO GROUP COMPANY

## IMPORTANT INFORMATION ON HOW TO USE THIS MANUAL

This OWNER'S MANUAL SUPPLEMENT is intended for use *in combination* with the “**Owner’s Manual for Electric Chain Hoist ED Series 125 through 525 Lb. Capacity**”. Refer to the Table of Contents below to determine the location(s) of information pertaining to your hoist. References to the “Owner’s Manual for Electric Chain Hoist ED Series 125 through 525 Lb. Capacity” will be designated by the use of the acronym “**EDOM**”.

### Table of Contents

<b>Section</b>	<b>Page Number</b>
1.0 Important Information and Warnings.....	EDOM
1.1 Terms and Summary	EDOM
1.2 Warning Tags and Labels	EDOM
2.0 Technical Information.....	4
2.1 Specifications	4
2.2 Dimensions	5
2.3 Part Names	7
3.0 Pre-operational Procedures.....	.8 and EDOM13
3.1 Fill Gear Box with Oil	EDOM
3.2 Chain	8
3.3 Load Chain Lubrication	EDOM
3.4 Chain Container	EDOM
3.5 Mounting Location	EDOM
3.6 Mounting the Hoist	9
3.7 Electrical Connections	EDOM
3.8 Pre-operational Checks and Trial Operation	EDOM
4.0 Operation.....	EDOM
4.1 Introduction	EDOM
4.2 Shall's and Shall Not's for Operation	EDOM

<b>Section</b>	<b>Page Number</b>
4.3 Hoist Controls	EDOM
4.4 Electric Chain Hoist with Trolley	EDOM
5.0 Inspection .....	10 and EDOM
5.1 General	EDOM
5.2 Inspection Classification	EDOM
5.3 Frequent Inspection	EDOM
5.4 Periodic Inspection	EDOM
5.5 Occasionally Used Hoists	EDOM
5.6 Inspection Records	EDOM
5.7 Inspection Methods and Criteria	10 and EDOM
6.0 Maintenance & Handling .....	EDOM
6.1 Lubrication	EDOM
6.2 Load Chain	EDOM
6.3 Mechanical Load Brake with Friction Clutch	EDOM
6.4 Fuses	EDOM
6.5 Storage	EDOM
6.6 Outdoor Installation	EDOM
7.0 Troubleshooting .....	EDOM
8.0 Warranty .....	EDOM
9.0 Parts List .....	12 and EDOM

## 2.0 Technical Information

### 2.1 Specifications

#### 2.1.1 Product Code

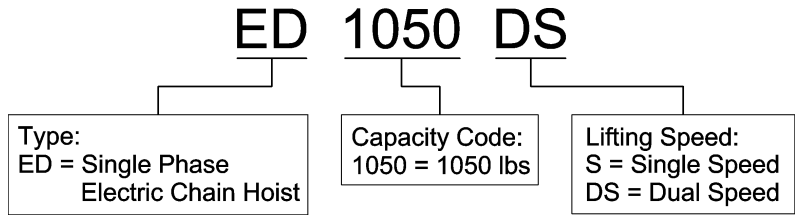

#### 2.1.2 Features and General Specifications

- Push Button Pendant Control – Standard
- Weight/Size – Light weight and compact size, easy to install, move, or store
- Double Braking System – A Weston style load brake and a regenerative brake
- Low Headroom – Die cast aluminum body provides low headroom, perfect for tight quarters
- Upper Limit Switch – Standard
- Over-Travel Protection – Friction clutch integrated with load brake and engineered to protect the hoist from overwinding
- Smooth Operation – Gears are immersed in an oil bath and have deep groove ball and needle bearings to support rotating components
- Corrosion Resistant Load Chain – Nickel-plated, heat treated alloy chain for long life
- Chain Container – Standard

#### 2.1.3 Operating Conditions and Environment

- Temperature range: -4° to +104°F (-20° to +40°C)
- Humidity: 85% or less
- Enclosure Rating: Hoist Body                    IP54  
Push Button Pendant                    IP65
- Supply Voltage: Standard 120V-1-60
- ASME Duty Classification: H2

Table 2-1 Hoist Motor Rating								
Cap. (lbs.)	Product Code		Motor		Intermittent Duty Rating		Short Time Duty Rating (min)	Rated Current at 120V (amps)
	Single Speed S Model	Dual Speed DS Model	Output (Hp)	Rated Current at 115V (Amps)	Duty Rating % ED	Max. Start Freq. (Times/Hr)		
1050	ED1050S	ED1050DS	0.8	10	30	180	15	10

Table 2-2 Hoist Specifications										
Cap. (lbs.)	Product Code		Lifting Speed (ft/min)		Load Chain Wire Diameter (mm) x Chain Fall Lines	Load Sheave Pockets	Net Weight (lbs.)		Weight for Additional One Foot of Lift (lbs.)	
	Single Speed S Model	Dual Speed DS Model	S Model	DS & DA Model			S Model	DS Model	S Model	DS Model
1050	ED1050DS	ED1050DS	22	22/6	4.0 x 2	5	46	47	0.49	0.52

## 2.2 Dimensions

Table 2-3 Hoist Dimensions												
Cap. (lbs.)	Headroom C (in)	Standard Lift L (ft)	Push Button Cord L (ft)	a (in)	d (in)	e (in)	f (in)	g (in)	h (in)	i (in)	j (in)	k (in)
	S & DS Model	S & DS Model	S & DS Model									
1050	20.5	10	8	16.9	8.1	8.8	9.0	0.9	6.1	2.9	1.0	17.9

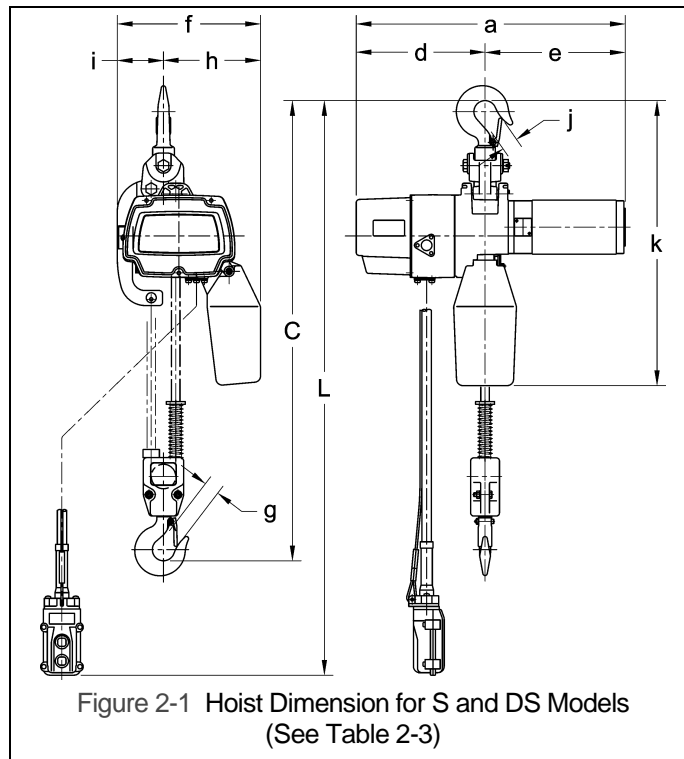

**Table 2-4 Hoist with Push or Geared Trolley Specifications**

Capacity (lbs)	Product Code		Lifting Speed (ft/min)		Standard Lift (ft)	Push Button Cord L (ft)	Motor Output (HP)	Intermittent Duty Rating		Short Time Duty Rating (min)	Rated Current at 120V (amps)	Adjustable Beam Width (in.)	Min. Radius for Curve (in)	Net Wt. (lbs)
	S & DS Model	S & DS Model	S Model	DS Model	S & DS Model	S & DS Model		Duty Rating % ED	Max. Start Freq. (Times/Hr)					
1050	with PTS2005	with GTS2010	22	22/6	10	8	0.8	30	180	15	10	2.28 – 4.00 (2.28 – 5.00)	43.3 (51.2)	55 (75)

FIGURES IN PARENTHESIS ARE DATA FOR GEARED TROLLEY.

**Table 2-5 Single Speed or Dual Speed Hoist with Push Trolley Dimensions**

Capacity (lbs)	Product Code		Headroom C (in)	a (in)	b (in)	e (in)	g (in)	h (in)	i (in)	j (in)	k (in)	m (in)	n (in)	r (in)	t (in)
	Hoist	Trolley													
1050	ED1050	PTS2005	20.5	8.0	7.2	1.8	0.9	3.2	2.36	0.7	3.0	1.9	3.3	1.5	0.87

**Table 2-6 Single Speed or Dual Speed Hoist with Geared Trolley Dimensions**

Capacity (lbs)	Product Code		Headroom C (in)	E (ft)	a (in)	b (in)	e (in)	g (in)	h (in)	i (in)	j (in)	k (in)	k' (in)	m (in)	n (in)	r (in)	t (in)	u (in)
	Hoist	Trolley																
1050	ED1050	GTS2010	21.0	7.5	13.6	9.3	6.0	0.9	4.2	2.80	1.1	3.7	4.2	2.2	4.4	2.0	0.98	7.2

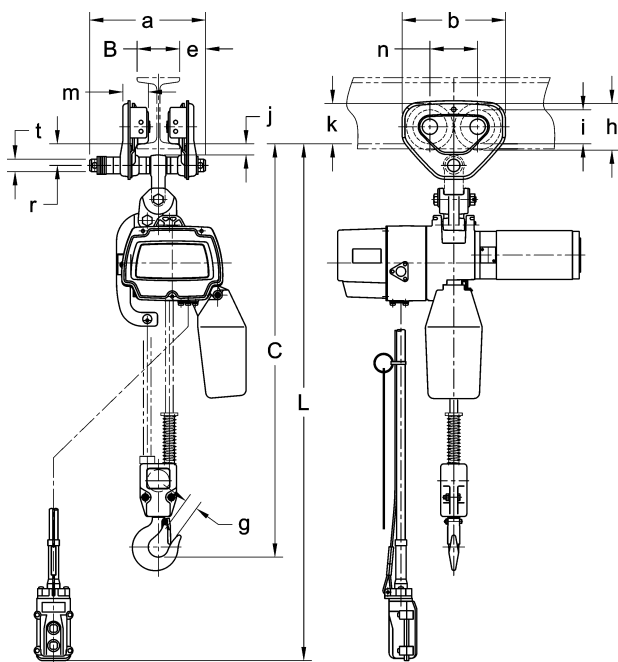

FIGURE 2-2 PUSH TROLLEY DIMENSION FOR S AND DS MODELS (SEE TABLE 2-5)

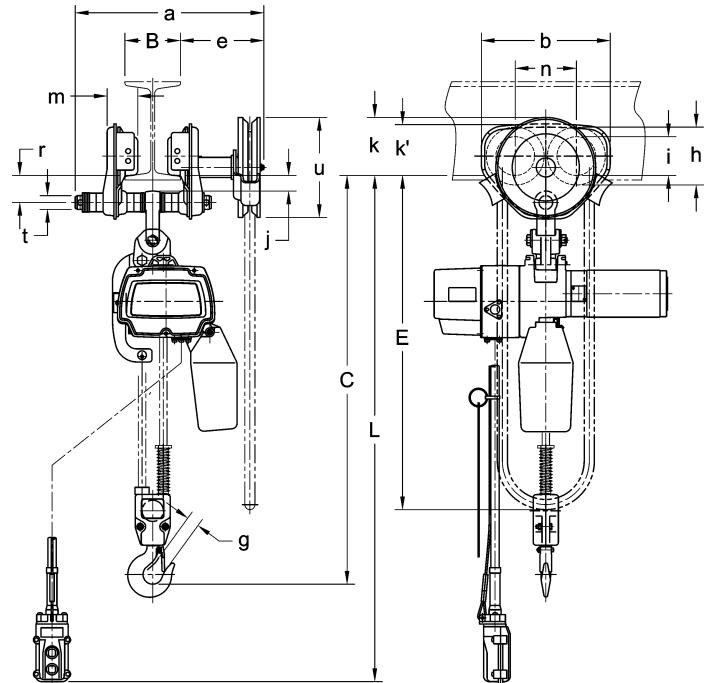

FIGURE 2-3 GEARED TROLLEY DIMENSION FOR S AND DS MODELS (SEE TABLE 2-6)

Table 2-7 ED1050 Hook Dimensions*								
Capacity (lbs.)	Hook	a (in)	b (in)	c (in)	d (in)	e (in)	f (in)	g (in)
1050	Top	1.1	0.7	0.9	0.7	1.4	1.2	1.1
	Bottom	1.1	0.7	0.9	0.7	1.4	1.4	0.9

\*See Table 5-5 for discard dimensions.

### 2.3 Part Names

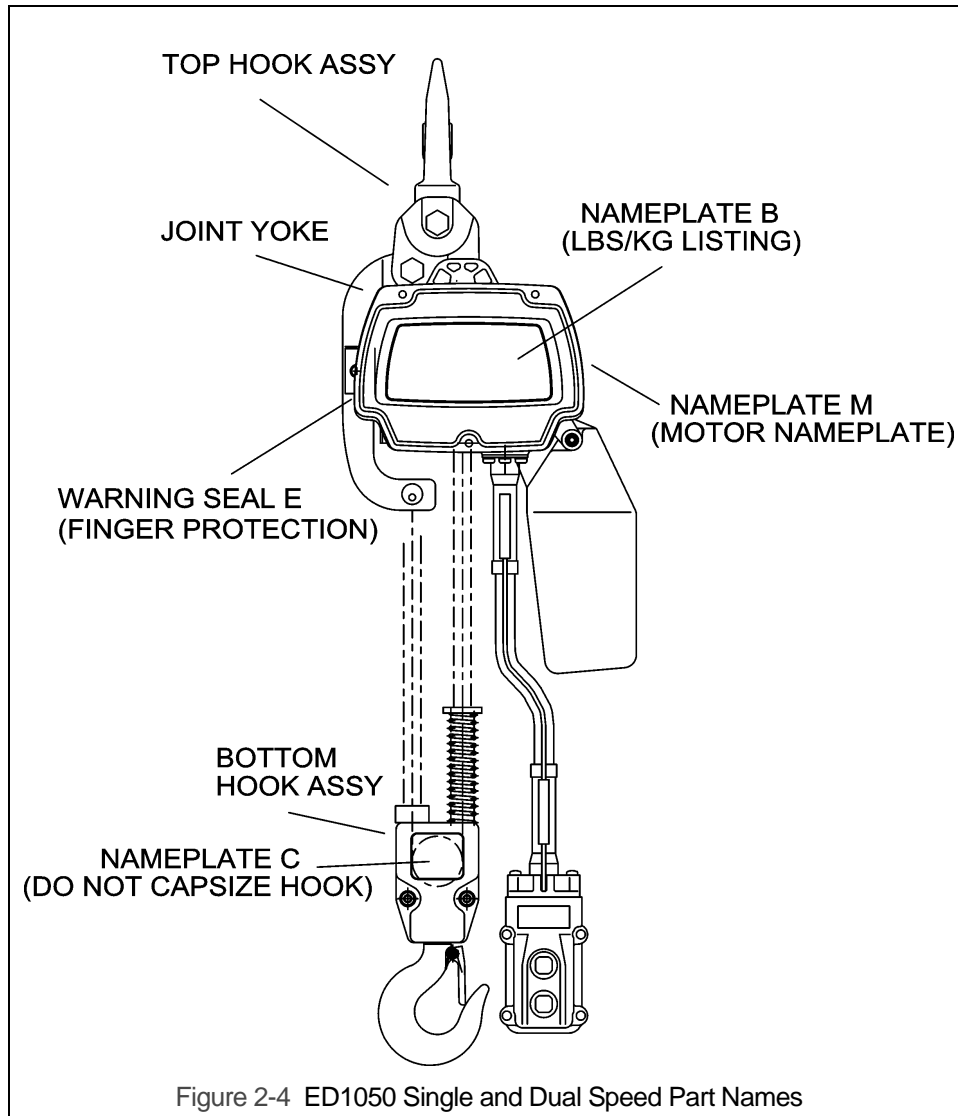

Figure 2-4 ED1050 Single and Dual Speed Part Names

# 3.0 Pre-operational Procedures

## 3.2.1 Chain

3.2.1 The quantity and location of the chain components including Cushion Rubbers, Washers and Stopper Assemblies is shown in Table 3-2, and Figure 3-2. Ensure that all chain components are in the correct location and properly installed. Never operate the hoist with incorrect, missing or damaged chain components.

Table 3-2 Chain Stopper Placement		
Capacity Code	Load Side	No Load Side
S & DS	Adjacent to bottom yoke	Last link

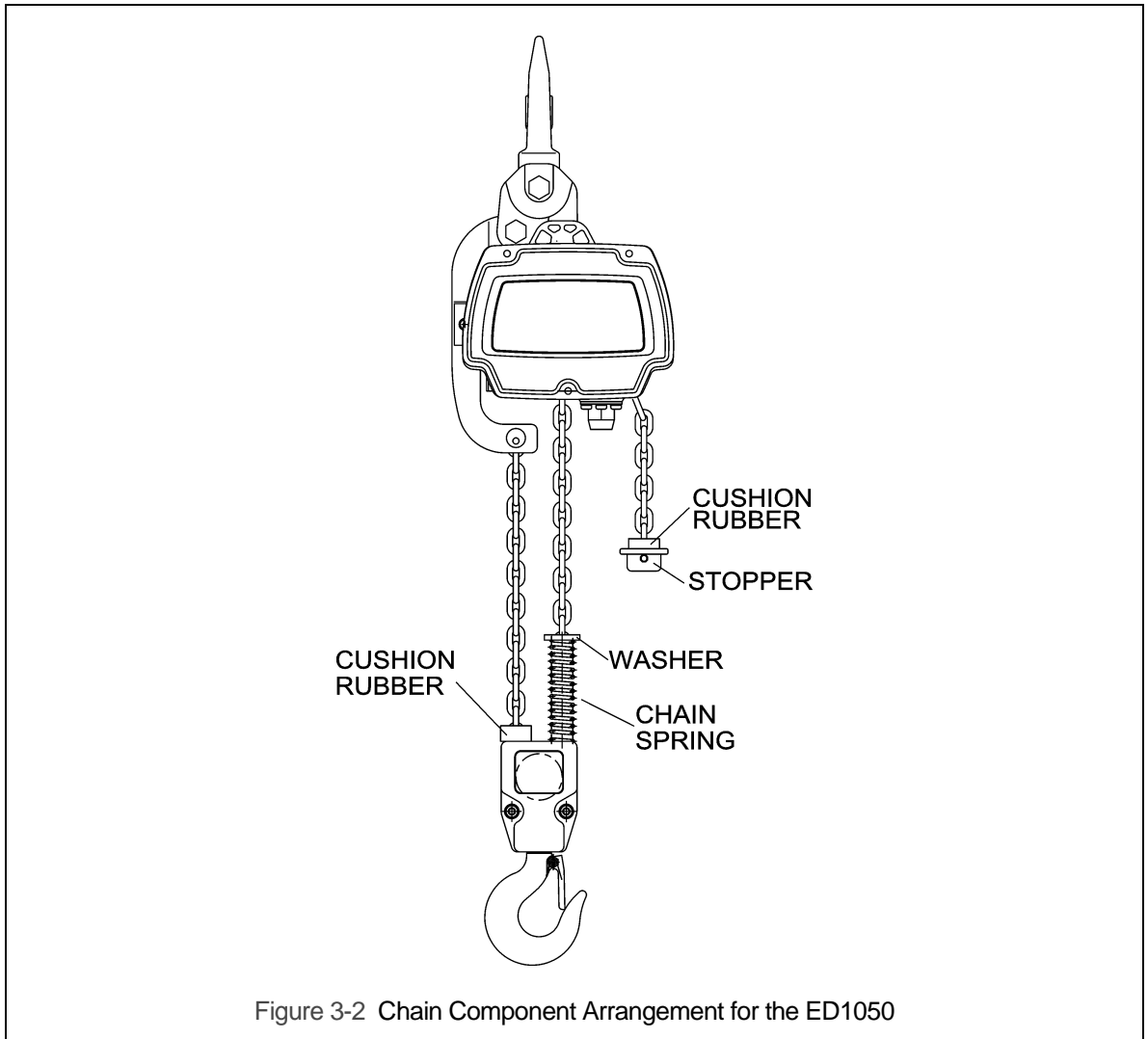



### 3.6 Mounting the Hoist

3.6.1 Manual Trolley - Follow instructions in Owner's Manual provided with the trolley.

3.6.2 Hook Mounted to a Fixed Location - Attach the hoist's top hook to the fixed suspension point.

3.6.3 **⚠️ WARNING** Ensure that the fixed suspension point rests on the center of the hook's saddle and the hook's latch is engaged.

## 5.0 Inspection

**NOTICE** The information listed in this section is intended to supplement Section 5.7 of the EDOM.

<b>Table 5-3 Hoist Inspection Methods and Criteria</b>			
<b>Use this table in conjunction with Table 5-3 of the EDOM. The entries in this table replace in their entirety the corresponding entries in Table 5-3 of the EROM.</b>			
<b>Item</b>	<b>Method</b>	<b>Criteria</b>	<b>Action</b>
Hooks - Idle Sheave and Axle (Bottom Hook on Double Fall Hoist)	Visual, Function	Pockets of Idle Sheave should be free of significant wear. Idle Sheave surfaces should be free of nicks, gouges, dirt and grime. Bearing parts and surfaces of Idle Sheave and Axle should not show significant wear. Idle Sheave should rotate freely with no roughness or significant free play.	Clean/lubricate, or replace as required.
Load Chain - Reeving	Visual	Chain should be reeved properly through Load Sheave (and Idle Sheave for double fall hoist) - refer to <b>Section 6.4</b> . Chain, Chain Spring, Cushion Rubbers, and Stoppers should be installed properly - refer to <b>Section 3.2</b> .	Reeve/Install chain properly.
Cushion Rubber	Visual	Should be free of significant deformation.	Replace.
Chain Springs	Visual	Chain springs should not be deformed or compressed.	Replace.

**Table 5-5 Top Hook & Bottom Hook Dimensions**

"k" Measured When New:

Top: \_\_\_\_\_

Bottom: \_\_\_\_\_

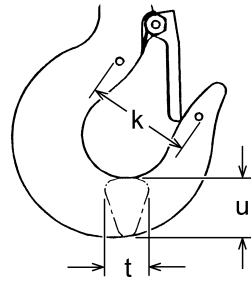

Capacity (lbs)	*Nominal "k" Dimension inch (mm)	"u" Dimension inch (mm)		"t" Dimension inch (mm)	
		Standard	Discard	Standard	Discard
1050	1.65(42)	0.93(23.5)	0.83(21)	0.69(17.5)	0.63(16)

\* These values are nominal since the dimension is not controlled to a tolerance. The **"k" dimension** should be measured when the hook is new - this becomes a reference measurement. Subsequent measurements are compared to this reference to make determinations about hook deformation/stretch. See EDOM Section 5.7, "Hooks - Stretch".

## 9.0 Parts List

When ordering Parts, please provide the Hoist code number, lot number and serial number located on the Hoist nameplate (see fig. below).

Reminder: Per sections 1.1 and 3.9.4 to aid in ordering Parts and Product Support, record the Hoist code number, lot number and serial number in the space provided on the cover of this manual.

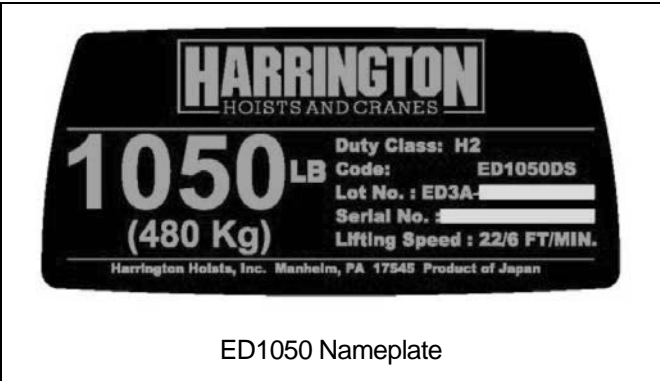

The parts list is arranged into the following sections:

Section	Page
9.1 ED1050 Additional Parts.....	14

A designator is used to distinguish parts that apply only to a particular model or option. Refer to Section 2 for hoist model numbers and additional descriptions. The designators are:

- S = Single Speed
- DS = Dual Speed

**This Page Intentionally Left Blank**

9.1 ED1050 ADDITIONAL PARTS

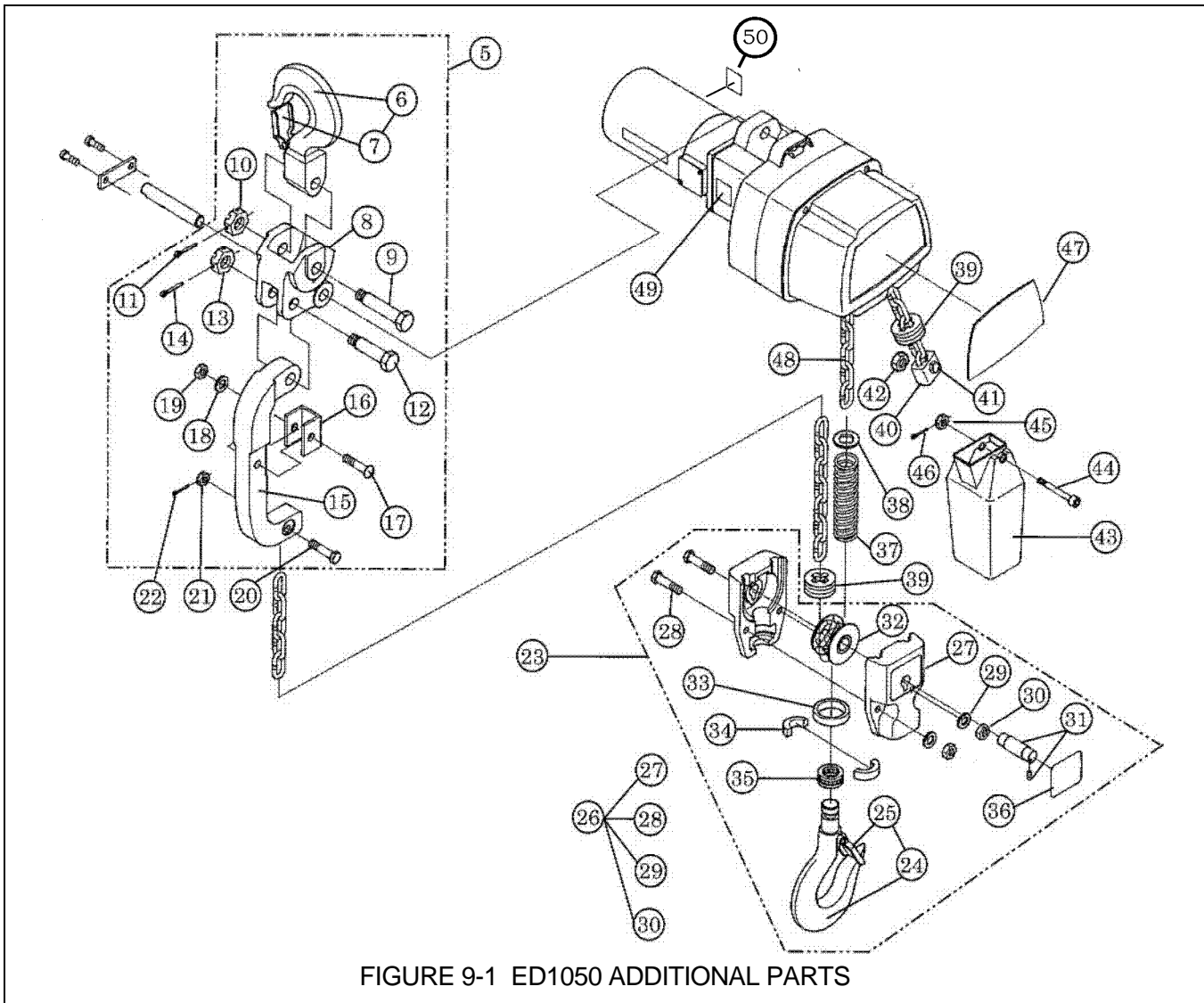

FIGURE 9-1 ED1050 ADDITIONAL PARTS

## 9.1 ED1050 ADDITIONAL PARTS

<b>Fig. No.</b>	<b>Part Number</b>	<b>Part Name</b>	<b>Qty Per Hoist</b>
5	E3DBX48S1470	Connection yoke complete set	1
6	E3DBX48S6460	Top hook assembly	1
7	CF071005	Hook Latch assembly	1
8	E3DBX48S9470	Connection yoke	1
9	ES006005L	Top Pin, L	1
10	L3183008	Slotted nut	1
11	9009403	Split pin	1
15	E3DBX48S9580	Joint yoke	1
16	E3DBX48S9592	Protection pad	1
17	J1AG25003535	Truss head machine screw	1
18	9012510	Washer	1
19	9098503	U nut	1
20	E2D041125	Chain pin	1
21	E2D049125	Slotted nut	1
22	9009402	Split pin	1
23	E3DHX48S1480	Bottom hook complete set	1
24	E3DBX48S2480	Bottom hook assembly	1
25	ER1BS1002	Hook latch assembly	1
26	E3DBX48S2485	Bottom yoke assembly	1
27	E3DBX48S9485	Bottom yoke	2
28	9093307	Bolt	2
29	9012709	Spring lock washer	2
30	9093420	Nut	2
31	E3DBX48S6489	Bottom shaft assembly	1
32	E3DBX48S6487	Idle sheave assembly	1
33	ES026003	Thrust collar A	1
34	ES027003	Hook stopper	2
35	ES022003	Thrust bearing	1
36	E3DBX48S9597	Name plate C	1
37	E3DBX48S9590	Chain spring	1
38	E3DBX48S9591	Washer	1

## 9.1 ED1050 ADDITIONAL PARTS

<b>Fig. No.</b>	<b>Part Number</b>	<b>Part Name</b>	<b>Qty Per Hoist</b>	
43	E2D1835125	Chain container	1	
	44	E2D854125	Socket bolt BP	1
	45	E2D853125	U nut	1
	46	9009402	Split pin	1
47	E3DHX48S9801	Name plate B, Single Speed	1	
	E3DHX48R9801	Name plate B, Dual Speed	1	
49	E3DBX48S9599	Warning Seal E (Finger protection)	1	
50	E3DHX48S9802	Nameplate M (Motor Nameplate)	1	



**This Page Intentionally Left Blank**

**This Page Intentionally Left Blank**

**This Page Intentionally Left Blank**



Harrington Hoists, Inc.  
401 West End Avenue  
Manheim, PA 17545

[www.harringtonhoists.com](http://www.harringtonhoists.com)

Toll Free: 800-233-3010  
Phone: 717-665-2000  
Fax: 717-665-2861

**EDOM1050SUP-ENG**