

PURPOSE

To provide dimensional information and specifications for the HPC500 Series Crane System.

TABLE OF CONTENTS

<u>Page</u>	<u>Type</u>	<u>Description</u>
2	Line Drawing	HPC500 Series Top Running
2	Data Chart	HPC500 Top Running Imperial Dimensions and Specifications
2	Data Chart	HPC500 Top Running Metric Dimensions and Specifications
3	Line Drawing	HPC500 Series Underhung
3	Data Chart	HPC500 Underhung Imperial Dimensions and Specifications
3	Data Chart	HPC500 Underhung Metric Dimensions and Specifications
4	Data Chart	HPC500 Series Recommended Bridge Beams

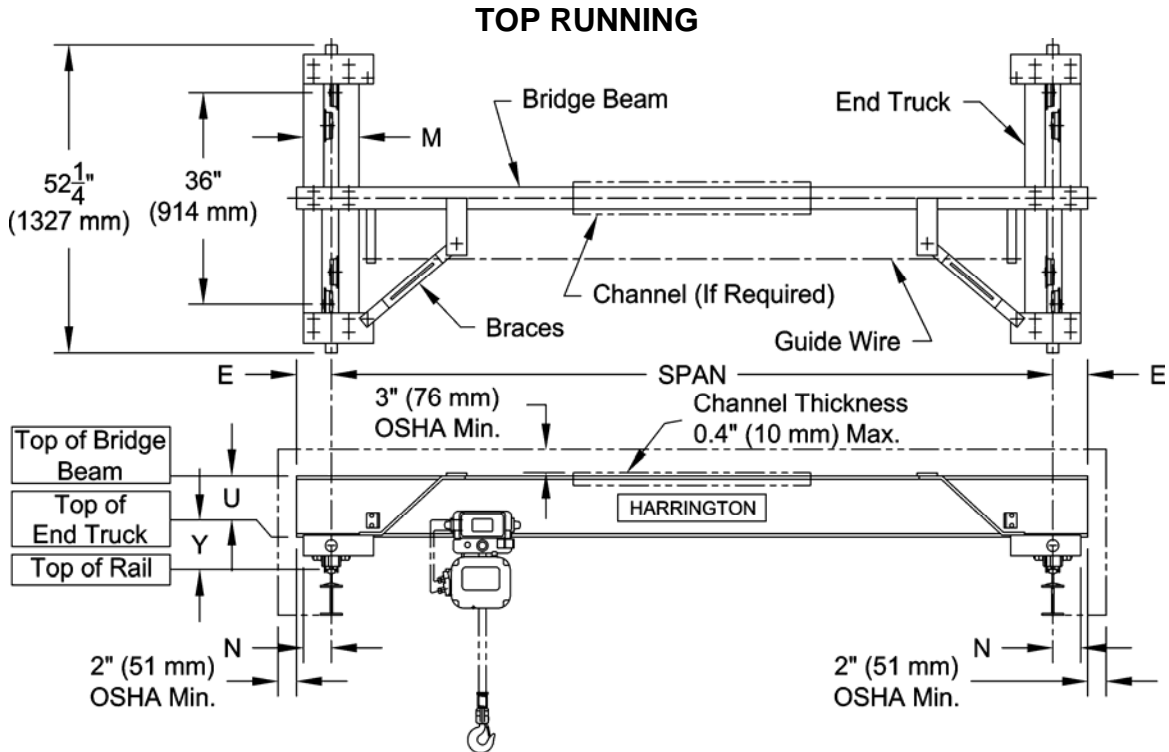

Imperial Top Running Specifications & Dimensions

Cap. (Tons)	Max. Span (ft)	Crane Product Code	Wheel Tread Dia. (in)	Rail Head Width* (in)	E** Beam Beyond Span (in)	M†† End Truck Frame Width (in)	N Runway Ctr. Line to Outer Edge of ET (in)	U*** Top of End Truck to Top of Beam (in)	Y Top of Rail to Top of End Truck (in)	System Max. Wheel Load† (lbs per wheel pair)
1/2	24	CHPC505	3.12	1.5 - 6	6	T + 7.3	M/2	Beam Depth****	4.3	841
1		CHPC510	4.00			T + 8.3			5.3	1500
2		CHPC520	4.88			5.9			2819	

Metric Top Running Specifications & Dimensions

Cap. (Tons)	Max. Span (m)	Crane Product Code	Wheel Tread Dia. (mm)	Rail Head Width* (mm)	E** Beam Beyond Span (mm)	M†† End Truck Frame Width (mm)	N Runway Ctr. Line to Outer Edge of ET (mm)	U*** Top of End Truck to Top of Beam (mm)	Y Top of Rail to Top of End Truck (mm)	System Max. Wheel Load† (kg per wheel pair)
1/2	7.3	CHPC505	79	38 - 152	152	T + 185	M/2	Beam Depth****	109	381.5
1		CHPC510	102			T + 211			135	680.4
2		CHPC520	124			150			1278.7	

* Consult factory for widths or flanges greater than 6" (152 mm).

** Minimum E is M/2

*** When using S6 beam, add 3/8" (10 mm) to U.

**** See recommended bridge beam chart. The number following the "S" is the beam depth.

† See explanation in Technical Information section of EDOC0096.

†† Formula shown is for S beams & ASCE rail. Add 1/4" (6 mm) for W beams and rectangular bar.

GENERAL USE

EDOC0180

Rev. 02 April 30, 2007

UNDERHUNG

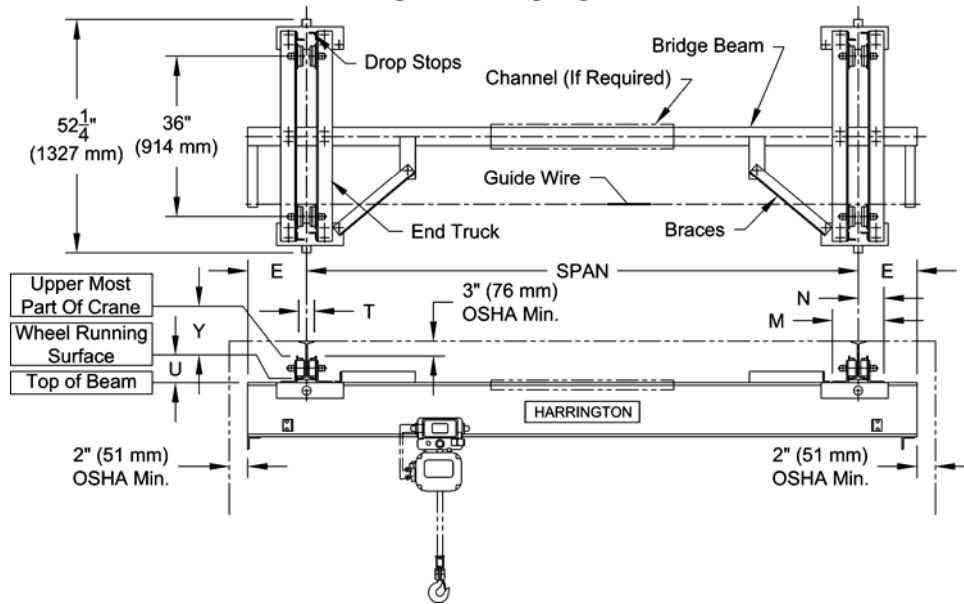

Imperial Underhung Specifications

Cap. (Tons)	Max. Span (ft)	Crane Product Code	Wheel Tread Dia. (in)	T* Flange Range Std. (in)	E** Beam Beyond Span (in)	M†† End Truck Frame Width (in)	N Runway Ctr. Line to Outer Edge of ET (in)	U*** Wheel Running Surface to Top of Beam (in)	Y Wheel Running Surface to Upper Most Part of Crane (in)	System Max. Wheel Load† (lbs per wheel pair)
1/2	24	CHPC505	3.12	3 - 6	12	T + 7.3	M/2	1.2	3.6	846
1		CHPC510	4.00			T + 8.3		1.2	4.4	1506
2		CHPC520	4.88	3.3 - 6		1.1		5.3	2827	

Metric Underhung Specifications

Cap. (Tons)	Max. Span (m)	Crane Product Code	Wheel Tread Dia. (mm)	T* Flange Range Std. (mm)	E** Beam Beyond Span (mm)	M†† End Truck Frame Width (mm)	N Runway Ctr. Line to Outer Edge of ET (mm)	U*** Wheel Running Surface to Top of Beam (mm)	Y Wheel Running Surface to Upper Most Part of Crane (mm)	System Max. Wheel Load† (kg per wheel pair)
1/2	7.3	CHPC505	79	76 - 152	305	T + 185	M/2	30	91	383.7
1		CHPC510	102			T + 211		30	112	683.1
2		CHPC520	124	84 - 152		28		135	1282.3	

* Consult factory for widths or flanges greater than 6" (152 mm).

** Minimum E is M/2

*** When using S6 beam, add 3/8" (10 mm) to U.

**** See recommended bridge beam chart. The number following the "S" is the beam depth.

† See explanation in Technical Information section of EDOC0096.

†† Formula shown is for S beams & ASCE rail. Add 1/4" (6 mm) for W beams and rectangular bar.

RECOMMENDED BRIDGE BEAMS

1. Includes 15% Allowance for Electric Hoist Load Factor.
2. Based on Harrington's electric chain hoist product.
3. For spans greater than 10 ft (3.0 m), braces between end truck and bridge beam are recommended.

Cap. (Tons)	Maximum Allowable Span: ft (m)			
	10 (3.0)	15 (4.6)	20 (6.1)	24 (7.3)
½	S8 X 18.4	S8 X 18.4	S8 X 18.4	S10 X 25.4
1	S8 X 18.4	S8 X 18.4	S10 X 25.4	S10 X 25.4
2	S10 X 25.4	S10 X 25.4	S12 X 31.8	S12 X 31.8 C8 X 11.5