

Heavy Duty Class C Single Girder Series 3 Top Running Complete Cranes

Harrington Top Running cranes are high-performance systems that easily handle today's most demanding Class "C" applications. Examples include fabricating, machining, die handling, production, assembly and maintenance. All bolted assembly makes installation quick and easy—no welding required. Most wiring connections are factory installed or plug-in type. You can rely on Harrington cranes for durability, reliability and years of trouble-free service. Count on Harrington to include standard features that are options on competitors' cranes.



Field adjustable Electronic Acceleration Control (EAC)
*for superior load control
(see page 30)*

Electric hoists feature 60 minute rating,
*fan cooled motor, and
low-maintenance
pull rotor brake*

Quick disconnect cords
*for ease of installation
and maintenance*

Forged carbon-steel hook
*capable of swiveling
360° under load*

All bolted construction
for ease in assembly

Side guide rollers on motorized trolleys for smooth movement

Convenient inspection port allows an inside look at gears

Totally enclosed, non-ventilated motor
ensures long life

Helical gears are induction-hardened
for extended life

Crane wiring enclosed
in conduit for code compliance

Cross bracing ensures crane rigidity for longer life

Bumpers and rail sweeps are standard on end trucks and powered trolleys

Adjustable DC brake
to control crane deceleration
(see page 32)

Standard electric trolley brake for ultimate load control

Structural steel, rectangular tube end truck design with machined steel wheels is compact for optimum end approach

Side guide rollers reduce wheel wear and provide smooth crane travel

Trolley hoist available in a wide selection of low headroom styles

Push-button pendant for easy control of trolley, hoist and bridge motion. Includes power on/off control

Heavy Duty Class C Single Girder Series 3 Top Running Motorized Complete Cranes

Many benefits from more features:

- Adjustable Electronic Acceleration Control (EAC) and adjustable brake allow customized speed control to avoid load swing and optimize load control.
- Standard rubber bumpers on cranes and motorized trolleys comply with ASME requirements.
- Side guide rollers reduce wheel friction and noise, providing smooth crane travel and increased wheel and runway life.
- Stationary crane wires are enclosed in conduit to comply with NEC requirements.
- Thermal motor protection is standard to protect motor from overheating.
- Electric hoists with ASME H4 rating maximize lifting capability while minimizing downtime and expense.
- Sealed motors enhance motor life and minimize repair costs.

Capabilities to count on:

- Capacities through 10 Ton and spans through 60 feet.
- Crane speeds: 40, 80, 120 ft./min. single speed, 80/20 ft./min. dual speed, or variable speed.
- Motorized trolley speeds: 40 or 80 ft./min. single speed, 80/20 ft./min. dual speed or variable speed. Also available with manual trolley (geared or push).
- Hoist speeds: See page 34.
- 3 phase voltages: 208, 230/460, 380, 575 (50 or 60 Hz).
- Suitable for use on ASCE crane rail or square bar.

Complete crane system includes:

- End trucks come standard with drives, brakes, bumpers, drop stops, and rail sweeps.
- Crane control panel with adjustable Electronic Acceleration Control (EAC) and thru-the-door lock-out disconnect switch. (See page 30.)
- Crane wiring installed in code-compliant conduit.
- Standard bridge beam assembly with bracing and capacity labels.
- Trolley hoist supplied with operator control pendant.
- Optional runway electrification.
- Documentation including assembly and installation instructions, crane operator's guide and owner's manuals.
- Touch-up paint.
- One year warranty.

Series 3 Top Running Motorized Single Girder Complete Cranes Dimensions

Cap. (Tons)	Max. Span (ft)	Crane Product Code	Wheel Dia. (in)	Sug. Min. Runway Rail (ASCE#)	A Overall Length (in)	B Roller Base (in)	D Wheel Base (in)	E Beam Beyond Span (in)	U Top of End Truck to Top of Beam (in)	X** Width Beyond Span (in)	Y Top of Rail to Top of End Truck (in)	G Motor (in)
1	35	CTML/S/H/D-3-0135	3.74	30	61	53	43	2.4	8.4 (10.4 for cranes using 10" beam)	4.6	7.1	12.7 (L/S)
	60	CTML/S/H/D-3-0160			98	90	80					13.1 (H)
3	35	CTML/S/H/D-3-0335	6.10	40	62	54	43	4.1	8.5	4.7	9.2	13.0 (L/S)
	60	CTML/S/H/D-3-0360			99	90	80					13.4 (H)
5	35	CTML/S/H/D-3-0535	8.27	60	62	54	43	6.0	12.5	6.3	11.3	14.3 (D)
	60	CTML/S/H/D-3-0560			99	90	74					15.0 (L/S/D)
10	35	CTML/S/H/D-3-1035	9.84	60	63	53	37	6.0	12.5	6.3	11.3	15.4 (D)
	60	CTML/S/H/D-3-1060			100	90	74					17.4 (L/S/D)

**Based on suggested minimum runway rail.

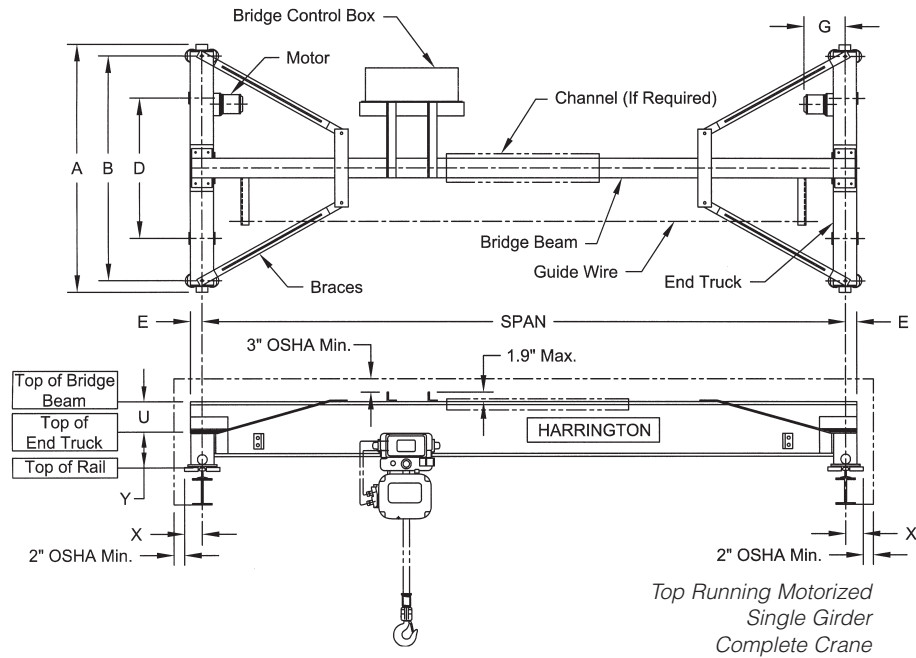

Series 3 Top Running Motorized Single Girder Complete Cranes Specifications

Crane Product Code	Speed Codes L and S			Speed Code H			Speed Code D			System Max. Wheel Load* (lbs/wheel)
	One Motor Per End Truck 3 Phase 60 Hz			One Motor Per End Truck 3 Phase 60 Hz			One Motor Per End Truck 3 Phase 60 Hz			
	Output (Hp)	Rated Current (amps ea.)		Output (Hp)	Rated Current (amps ea.)		Output (Hp)	Rated Current (amps ea.)		
	@230V	@460V		@230V	@460V		@230V	@460V		
CTML/S/H/D-3-0135	0.33	1.6	1.0	0.5	2.1	1.3	0.33/0.1	1.6/1.1	0.9/0.8	1,980
CTML/S/H/D-3-0160										2,840
CTML/S/H/D-3-0335										4,440
CTML/S/H/D-3-0360										5,690
CTML/S/H/D-3-0535	0.5	2.1	1.3	1.0	3.3	2.0	0.5/0.1	2.0/1.5	1.2/0.9	6,910
CTML/S/H/D-3-0560										8,450
CTML/S/H/D-3-1035	1.0	3.3	2.0	2.0	5.8	3.1	1.0/0.6	3.7/2.1	2.3/1.4	13,500
CTML/S/H/D-3-1060										15,050

*See definition on page 28.

Speed Code

- L - Designates 40 ft/min
- S - Designates 80 ft/min
- H - Designates 120 ft/min
- D - Designates dual speed 80/20 ft/min

Product Code Derivation - example: CTML-3-0135

- CT - Complete Top Running Crane
- M - Motorized
- L - Speed of 40 ft/min
- 3 - Series number
- 01 - Max. capacity - 1 Ton
- 35 - Maximum span - 35 feet

Heavy Duty Class C Single Girder Series 3 Top Running Geared Complete Cranes

Harrington's top running geared cranes offer an economical alternative to motorized systems. Side guide rollers mean these cranes operate much easier than flanged wheel cranes. Consider geared operation where precision control is required, such as die handling or fabrication assembly operations. Geared cranes are easily upgradeable to motorized systems to meet changing customer needs.

Many benefits from more features:

- Ideal for precision spotting requirements where motorized operation is not necessary.
- Standard rubber bumpers on cranes and motorized trolleys comply with ASME requirements.
- Side guide rollers reduce wheel friction and noise, providing smooth crane travel and increased wheel and runway life.
- Electric hoists with ASME H4 rating maximize lifting capability while minimizing downtime and expense.
- Sealed hoist and trolley motors enhance motor life and minimize repair costs.

Capabilities to count on:

- Capacities through 5 Ton and spans through 50 feet.
- Motorized trolley speeds: 40 or 80 ft./min. single speed, 80/20 ft./min. dual speed or variable speed. Manual trolleys also available (push or geared).
- Hoist speeds: See page 34.
- Suitable for use on ASCE crane rail or square bar.

Complete crane system includes:

- End trucks come standard with bumpers, drop stops, and rail sweeps.
- Drive shaft assembly with hand wheel and hand chain.
- Standard bridge beam assembly with bracing and capacity labels.
- Trolley hoist available in a wide selection of styles.
- Power supply to trolley hoist (if required).
- Optional runway electrification.
- Documentation including assembly and installation instructions, crane operator's guide, and owner's manuals.
- Touch-up paint.
- One year warranty.

Series 3 Top Running Geared Single Girder Complete Cranes Specifications & Dimensions

Cap. (Tons)	Max. Span (ft)	Crane Product Code	Wheel Dia. (in)	Sug. Min. Runway Rail (ASCE#)	A Overall Length (in)	B Roller Base (in)	D Wheel Base (in)	E Beam Beyond Span (in)	J Hand Wheel Offset (in)	U Top of End Truck to Top of Beam (in)	X* Width Beyond Span (in)	Y Top of Rail to Top of End Truck (in)	System Max. Wheel Load** (lbs/wheel)
1	35	CTG-3-0135	3.74	30	61	53	43	2.4	9.7	8.4 (10.4 for cranes using 10" beam)	4.6	7.1	1,770
	50	CTG-3-0150			98	90	80						2,570
3	35	CTG-3-0335	6.10	40	62	54	43	4.1	10.0	8.5	4.7	9.2	4,400
	50	CTG-3-0350			99	91	80						5,060
5	35	CTG-3-0535	8.27	40	62	54	43	3.9	10.3	8.5	4.7	9.3	6,860
	50	CTG-3-0550			99	90	74						7,700

*Based on suggested minimum runway rail.

**See definition on page 28.

***Standard hand chain drop is 8 ft. from top of runway rail.

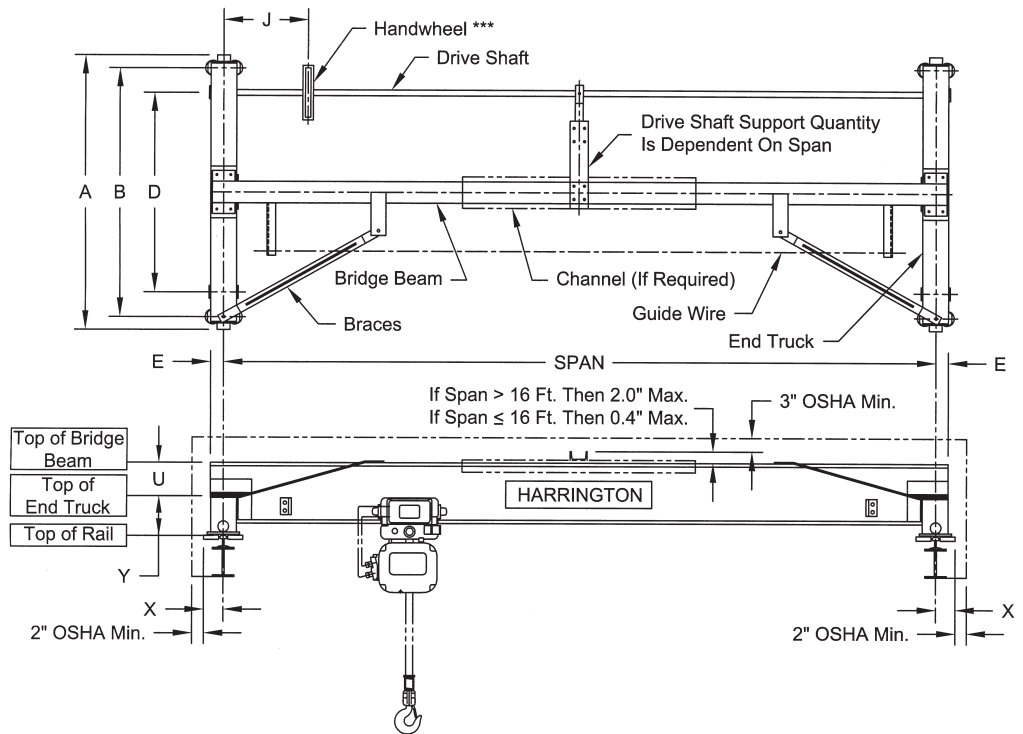

Top Running Geared Single Girder Complete Crane

Heavy Duty Class C Single Girder Series 3 Top Running Push Complete Cranes

Harrington's top running push cranes offer an economical alternative to other cranes. Side guide rollers mean these cranes operate much easier than flanged wheel cranes. Push cranes are easily upgradeable to motorized or geared operations to meet changing customer needs.

Many benefits from more features:

- Side guide rollers reduce wheel friction and noise, providing smooth crane travel and increased wheel and runway life.
- Compared to flanged wheel cranes, Harrington's push cranes operate easily, particularly in long span or long lift applications.
- Standard rubber bumpers on cranes and motorized trolleys comply with ASME requirements.
- Electric hoists with ASME H4 rating maximize lifting capability while minimizing downtime and expense.
- Sealed hoist and trolley motors enhance motor life and minimize repair costs.

Capabilities to count on:

- Capacities through 5 Ton and spans through 45 feet.
- Motorized trolley speeds: 40 or 80 ft./min. single speed, 80/20 ft./min. dual speed or variable speed. Manual trolleys also available (push or geared).
- Hoist speeds: See page 34.
- Suitable for use on ASCE crane rail or square bar.

Complete crane system includes:

- End trucks come standard with bumpers, drop stops, and rail sweeps.
- Standard bridge beam assembly with bracing and capacity labels.
- Trolley hoist available in a wide selection of styles.
- Power supply to trolley hoist (if required).
- Optional runway electrification.
- Documentation including assembly and installation instructions, crane operator's guide, and owner's manuals.
- Touch-up paint.
- One year warranty.

Series 3 Top Running Push Single Girder Complete Cranes Specifications & Dimensions

Cap. (Tons)	Max. Span (ft)	Crane Product Code	Wheel Dia. (in)	Sug. Min. Runway Rail (ASCE#)	A Overall Length (in)	B Roller Base (in)	D Wheel Base (in)	E Beam Beyond Span (in)	U Top of End Truck to Top of Beam (in)	X* Width Beyond Span (in)	Y Top of Rail to Top of End Truck (in)	System Max. Wheel Load** (lbs/wheel)
1	35	CIP-3-0135	3.74	30	61	53	43	2.4	8.4 (10.4 for cranes using 10" beam)	4.6	7.1	1,760
	45	CIP-3-0145			98	90	80					2,140
2	45	CIP-3-0245	6.10	40	99	91	80	4.1	8.5	4.7	9.2	6,410
3	35	CIP-3-0335			62	54	43					4,410
5	35	CIP-3-0535			62	54	43					6,850

*Based on suggested minimum runway rail.
 **See definition on page 28.

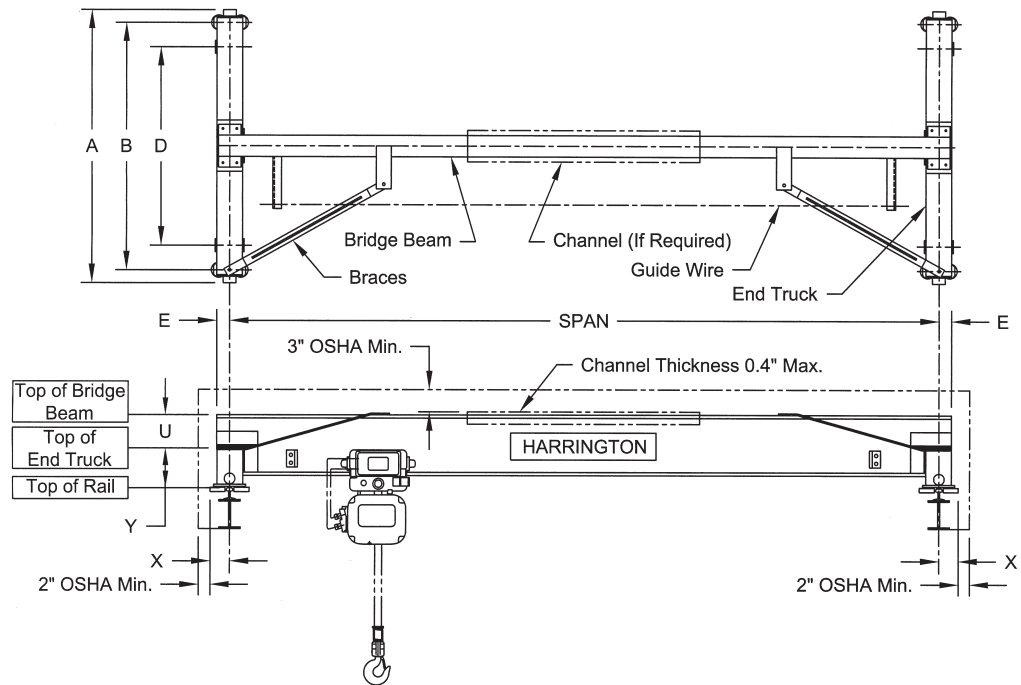

Top Running Push
 Single Girder
 Complete Crane