OWNER'S MANUAL SUPPLEMENT

ELECTRIC CHAIN HOIST NER2 / MR2 / TS2 FOOD GRADE MODEL

1/4 Ton through 2 Ton Capacities

Code, Lot and Serial Number

WARNING

This equipment should not be installed, operated or maintained by any person who has not read and understood all the contents of this manual. Failure to read and comply with the contents of this manual can result in serious bodily injury or death, and/or property damage.

HARRINGTON
A **KITO** GROUP COMPANY



IMPORTANT INFORMATION ON HOW TO USE THIS MANUAL

This OWNER'S MANUAL SUPPLEMENT for Food Grade Hoists is intended for use *in combination* with:

“Owner’s Manual for Electric Chain Hoist ER2 and NER2 Series 1/8 through 5 Ton Capacity”

“Owner’s Manual for Motorized Trolley MR2 Series 1 Ton through 20 Ton Capacity”

“Owner’s Manual for Manual Trolley TS2/TF2 Series ½ Ton through 5 Ton Capacity”

Refer to the Main Table of Contents below to determine the location(s) of information pertaining to your hoist. References to the Owner’s Manuals listed above will be designated by the use of the acronym “ER2OM”, “MR2OM”, “TF2TS2OM”.

Main Table of Contents

Chapters	Page Number
I	Conformance Clarification Statement.....3
II	NER2 Electric Chain Hoist.....4
III	MR2 Motorized Trolley.....11
IV	TS2 Manual Trolley.....15
V	Parts List.....21
	1.0 NER2.....21
	2.0 MR2.....43
	3.0 TS2.....59

I Conformance Clarification Statement

1.1 Food Grade Options

NOTICE

Harrington ER2 Food Grade hoists are designed for applications which require food grade hoists. All products should be tested for suitability on a particular application prior to actual use. The occupational Safety and Health Act of 1970 places the burden of compliance with the owner/employer, not the manufacturer. Many OSHA requirements are not concerned or connected with the manufactured product but are associated with the final installation. It is the owner's and user's responsibility to determine the suitability of a product for any particular use. It is recommended that all applicable industry, trade association, federal, state and local regulations be checked. Read all operating instructions and warnings before operation.

1.2 Corrosion Resistance:

Standard Product Features and Benefits

- Nickel plated load chain
- The formulation of NEVASTANE HD2T oils complies with the FDA chapter 21 CFR, 178.3570.
- The formulation of NEVASTANE XSH oils complies with the FDA chapter 21 CFR, 178.3570.
- White epoxy painted hoist body, hooks, and suspenders
- ASME H4 classification
- Stainless steel and nickel plated components

Optional Product Features and Benefits

- Nickel Diffused Load Chain
- Stainless Steel Trolley Wheels
- Nickel Plated shafts and suspenders
- NEMA 4 pendant
- Pendant Cover
- Stainless Steel bottom hook
- Stainless Steel chain spring and limiting plate
- Stainless Steel chain container

II NER2 Electric Chain Hoist

Section	Page Number
1.0 Important Information and Warnings	ER2OM
1.1 Terms and Summary	
1.2 Warning Tags and Labels	
2.0 Technical Information.....	6
2.1 Specifications	
2.2 Dimensions	
3.0 Preoperational Procedures	ER2OM
3.1 Gearbox	
3.2 Chain	
3.3 Mounting Location	
3.4 Mounting the Hoist	
3.5 Electrical Connections	
3.6 VFD Setup (Dual Speed Only)	
3.7 Preoperational Checks and Trial Operation	
4.0 Operation	ER2OM
4.1 Introduction	
4.2 Shall's and Shall Not's for Operation	
4.3 Hoist Controls	
5.0 Inspection	ER2OM
5.1 General	
5.2 Inspection Classification	
5.3 Frequent Inspection	
5.4 Periodic Inspection	
5.5 Occasionally Used Hoists	
5.6 Inspection Records	
5.7 Inspection Methods and Criteria	

Section	Page Number
6.0 Maintenance & Handling	ER2OM
6.1 Count/Hour Meter	
6.2 Lubrication – Load Chain, Hooks and Suspension.....	8 and ER2OM
6.3 Lubrication – Gearbox.....	8 and ER2OM
6.4 Motor Brake	
6.5 Load Chain.....	10 and ER2OM
6.6 Friction Clutch and Mechanical Load Brake with Friction Clutch	
6.7 Storage	
6.8 Outdoor Installation	
6.9 Operational Environment	
7.0 Troubleshooting	ER2OM
8.0 Warranty	ER2OM
9.0 Parts List	21

2.1 Specifications

2.1.1 Product Code

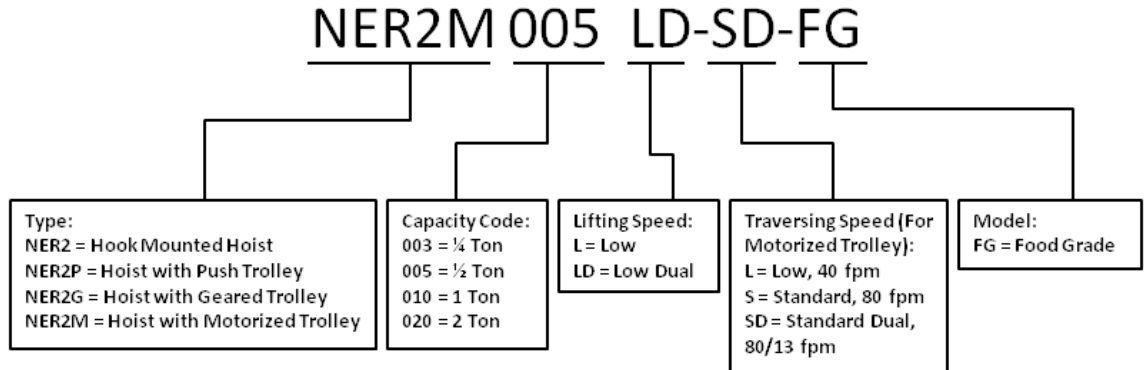

2.1.2 Operating Conditions and Environment

- Temperature range: -4° to +104°F (-20° to +40°C)
- Humidity: 85% or less
- Noise Level: 85 dB or less (A scale: measured 1 meter away from electric chain hoist)
- Enclosure Rating: Hoist Meets IP 55
- Supply Voltage: Single Speed Standard: Reconnectable 208/230-3-60 & 460V-3-60
Dual Speed Standard: 208/230V-3-60 or 460V-3-60

	Single Speed	Dual Speed
Hoist Duty Rating:	ISO M4/M5; ASME H4	
Intermittent Duty Rating:	60% ED 360 starts per hour	40/20% ED 120/240 starts per hour
Short Time Duty Rating:	60 min.	30/10 min.

	Cap. (Tons)	Product Code	Standard Lift (ft)	Push Button Cord L (ft)	Lifting Speed (ft/min)	Lifting Motor 3 Phase 60 Hz			Load Chain Diameter (mm) x Chain Fall Lines	Net Weight (lbs)	Weight for Additional One Foot of Lift (lbs)	
						Output (Hp)	Rated Current (amps)					
							@208 - 230V	@460V				
Single Speed	1/4	NER2003L-FG	10	8.2	15	0.75	3.4	1.7	6.0 x 1	71	0.54	
	1/2	NER2005L-FG				14	1.2	4.8	2.5	7.7 x 1	104	0.89
	1	NER2010L-FG			2.4		8.6	4.2	10.2 x 1	161	1.6	
	2	NER2020L-FG			15/2.5	0.75	3.6	1.8	6.0 x 1	68	0.54	
Dual Speed	1/4	NER2003LD-FG				14/2.5	1.2	5.1	2.7	7.7 x 1	99	0.89
	1/2	NER2005LD-FG					2.4	9.1	4.5	10.2 x 1	161	1.6
	1	NER2010LD-FG										
	2	NER2020LD-FG										

2.2 Dimensions

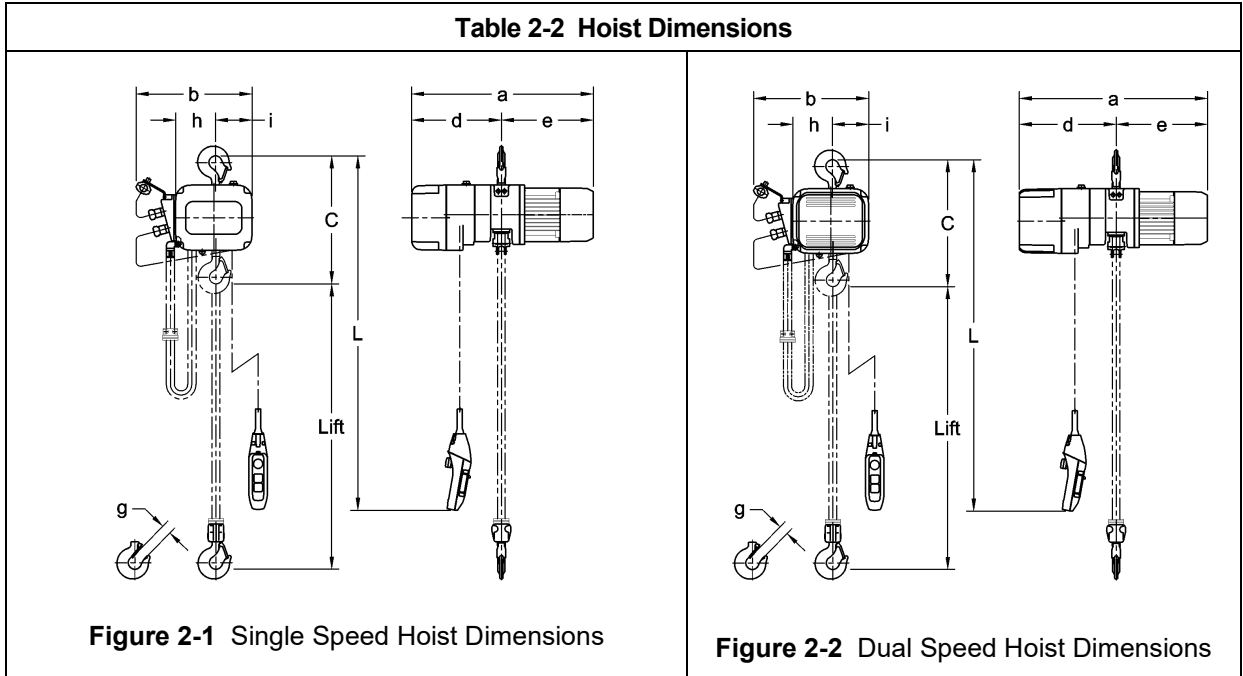

	Capacity (Tons)	Product Code	Headroom C (in)	Headroom w/Stainless Hook C (in)	a (in)	b (in)	d (in)	e (in)	g (in)	g w/Stainless Hook (in)	h (in)	i (in)
Single Speed	1/4	NER2003L-FG	14.6	17.7	20.2	13.7	9.5	10.6	1.1	1.2	4.4	4.2
	1/2	NER2005L-FG										
	1	NER2010L-FG	16.9	21.2	23.2	14.8	11.4	11.7	1.2	1.5	5.1	4.6
	2	NER2020L-FG	22.6	23.4	25.4	16.8	12.1	13.3	1.6	1.7	6.3	5.4
Dual Speed	1/4	NER2003LD-FG	14.6	17.7	22.4	13.7	11.8	10.6	1.1	1.2	4.4	4.2
	1/2	NER2005LD-FG										
	1	NER2010LD-FG	16.9	21.3	24.1	14.8	12.4	11.7	1.2	1.5	5.1	4.6
	2	NER2020LD-FG	22.6	23.4	27.9	16.8	14.6	13.3	1.6	1.7	6.3	5.4

Table 2-3 Hook Dimensions

T = Top Hook
B = Bottom Hook

Capacity Code	Hook	a (in)	b (in)	c (in)	d (in)	e (in)	f (in)	g (in)	h (in)
003L, 005L, 003LD, 005LD	Stainless Bottom	1.5	0.9	1.2	0.9	1.7	1.8	1.2	4.3
	Epoxy Painted Top & Bottom	1.1	0.7	0.9	0.7	1.4	1.5	1.1	3.7
010L, 010LD	Stainless Bottom	1.9	1.1	1.6	1.1	2.0	2.2	1.5	5.4
	Epoxy Painted Top & Bottom	1.5	0.9	1.2	0.9	1.7	1.8	1.2	4.3
020L, 020LD	Stainless Bottom	2.2	1.4	1.9	1.4	2.4	2.5	1.7	6.3
	Epoxy Painted Top & Bottom	2.0	1.3	1.7	1.3	2.1	2.2	1.5	5.7

6.2 Lubrication – Load Chain, Hooks, and Suspension

6.2.1 Load Chain

- For longer life, the load chain should be lubricated.
- The load chain lubrication should be accomplished after cleaning the load chain with an acid free cleaning solution.
- Apply only Harrington Hoist, Inc. food grade lubricant (Part No. 2AFG003S1951) to the bearing surfaces of the load chain links as indicated by the shaded areas in Figure 6-2. Also apply the lubricant to the areas of the load chain (shaded areas in Figure 6-2) that contact the load sheave. Ensure that the lubricant is applied to the contact areas in the load sheave pockets.

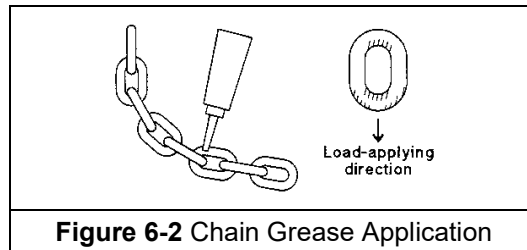

- The load chain should be lubricated every 3 months (more frequently for heavier usage or severe conditions).

6.2.2 Hooks and Suspension Components

- Hooks – Bearings should be cleaned and lubricated at least once per year for normal usage. Use only Nevastane HD2T White Drum food grade lubricating grease. Clean and lubricate more frequently for heavier usage or severe conditions.
- Suspension Pins – Lubricate at least twice per year for normal usage; more frequently for heavier usage or severe conditions.

6.3 Lubrication - Gearbox

6.3.2 **DETERMINING OIL LIFE** - Refer to Section 6.1.3 in the ER2OM when estimating gear oil life based on operations.

6.3.3 **NER2 OIL LEVEL** – The oil level is checked by removing the oil plug on the side of the hoist as shown in Figure 6-3 for NER2 hoists. The oil level should be just below the hole when the hoist is level.

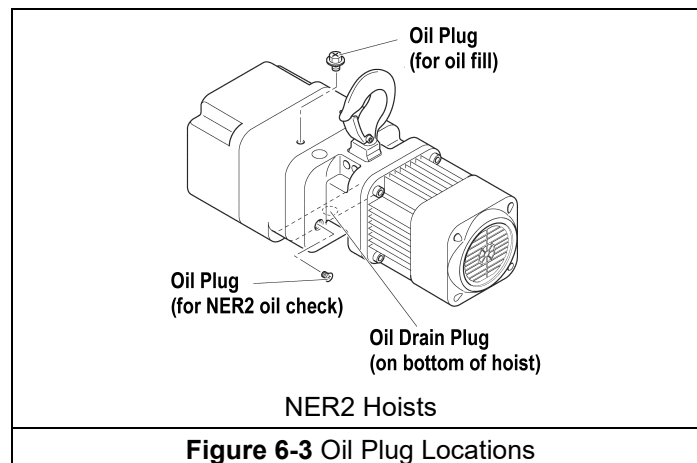

6.3.5 **REPLACING OIL** – Change gear oil at least once every 5 years. The oil should be changed more frequently depending on the hoist’s usage and operating environment. Refer to Section 6.1.3. Follow the procedure below for replacing the gearbox oil for your hoist:

- To drain the current oil from the hoist remove “Oil Plug” on top of the hoist and the “Oil Drain plug” on the bottom of the hoist. Allow the old oil to drain completely. Refer to Figure 6-4 for oil plug locations.

- **NOTICE** Dispose of the used oil in accordance with local regulations.

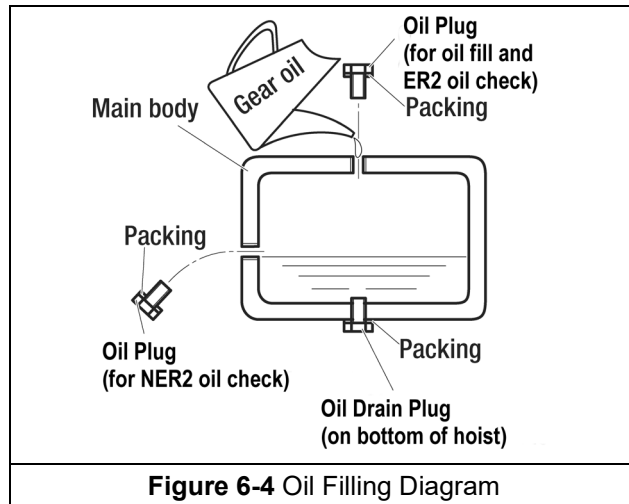

- Ensure that the oil plugs for the oil level check holes and the drain hole are reinstalled and secured into the hoist body.
- Refill the gear case with the correct quantity and type of new oil or until the oil level is within the range shown in Table 6-6. Refer to Figure 6-4.

Capacity Code	Quarts	Liters
	NER2	NER2
003L/005L	0.57	0.54
010L	0.66	0.62
020L	1.37	1.30

- **WARNING** Using an incorrect type/grade of gearbox oil or the wrong quantity of oil may prevent the friction clutch from working properly and may affect the ability of the hoist to hold the load. Only lubricants with NSF H1 compliance may be used in food grade hoists. Refer to the following for the correct type of gearbox oil:

NER Gear Oil:

- Harrington standard: Nevastane **XSH320** (Total Lubricants)

6.5 Load Chain

6.5.2 After chaining a unit, be sure to clean any exposed portions of bottom yoke bolts that have been treated with thread locking compound. Conduct a thorough inspection of these bolts after torquing to ensure there is no excess thread locking compound on the exposed portions. Failure to do so could affect the hoist's compliance with the application's food grade requirements.

III MR2 Motorized Trolley

Section	Page Number
1.0 Important Information and Warnings.....	MR2OM
1.1 Terms and Summary	
1.2 Warning Tag and Labels	
2.0 Technical Information.....	13
2.1 Specifications	
2.2 Dimensions	
3.0 Pre-operational Procedures.....	MR2OM
3.1 Assembly and Adjustment	
3.2 Mounting Location	
3.3 Installation of Trolley onto Beam	
3.4 Electrical Connections	
3.5 VFD Setup (Dual Speed Only)	
3.6 Pre-operational Checks and Trial Operation	
4.0 Operation.....	MR2OM
4.1 Introduction	
4.2 Shall's and Shall Not's for Operation	
4.3 Trolley and Hoist Controls	
5.0 Inspection.....	MR2OM
5.1 General	
5.2 Inspection Classification	
5.3 Frequent Inspection	
5.4 Periodic Inspection	
5.5 Occasionally Used Trolleys	
5.6 Inspection Records	
5.7 Inspection Methods and Criteria	

Section	Page Number
6.0 Maintenance & Handling.....	MR2OM
6.1 Count/Hour Meter (Dual Speed Only)	
6.2 Lubrication.....	14 and MR2OM
6.3 Brake	
6.4 Storage	
6.5 Outdoor Installation	
6.6 Operational Environment	
7.0 Troubleshooting.....	MR2OM
8.0 Warranty.....	MR2OM
9.0 Parts List.....	43

2.0 Specifications

2.1.1 Product Code for MR2 Trolley Alone:

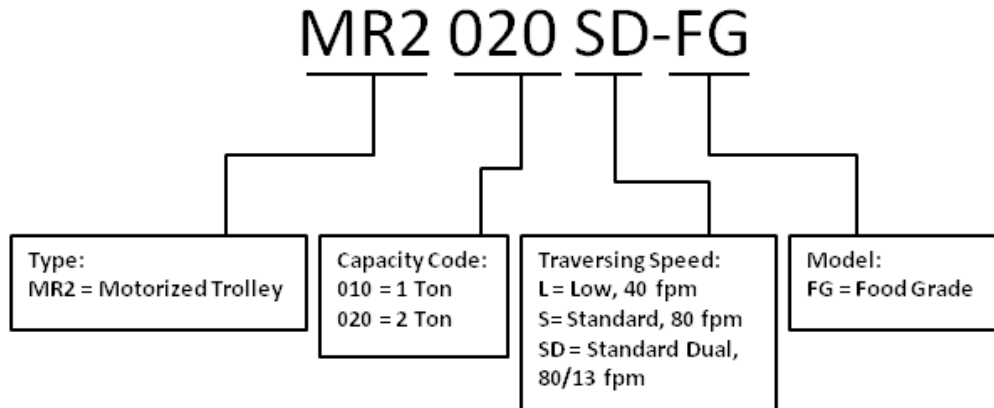

2.1.2 Operating Conditions and Environment

Temperature Range: -4° to +104°F (-20° to +40°C)

Humidity: 85% or less (no condensation)

Noise Level: 85 dB or less (A scale: measured 1 meter away from the electric chain hoist)

Enclosure Rating: Trolley Meets IP55, Pendant Meets IP 65

Supply Voltage: Standard 208-230/460V-3-60, Optional 575V-3-60, Special Voltages Available

Intermittent Duty Rating: Single Speed – 40% ED 240 starts per hour
Dual Speed – 27/13% ED with 78/162 starts per hour

Trolley Duty Rating: ISO M4/5; ASME H4

Table 2-1 Trolley Specifications									
	Capacity (Ton)	Product Code	Standard Beam Flange Range (in)	Optional Beam Flange Range (in)	Min. Allowable Radius for Curve (in)	Motor***			Approx. Net Weight (lbs)
						Output (Hp)	Current Draw (amps)		
							208V or 230V	460V	
Single Speed	1	MR2010L/S-FG	2.28 to 5.00	5.01 to 6.02 <u>OR</u> 6.03 to 12.00	31.5*	0.54	3.0	1.5	68
	2	MR2020L/S-FG	3.23 to 6.02	6.03 to 7.02 <u>OR</u> 7.03 to 12.00	31.5**	0.54	3.0	1.5	84
Dual Speed	1	MR2010SD-FG	2.28 to 5.00	5.01 to 6.02 <u>OR</u> 6.03 to 12.00	31.5	0.54	3.0	1.5	75
	2	MR2020SD-FG	3.23 to 6.02	6.03 to 7.02 <u>OR</u> 7.03 to 12.00	31.5	0.54	3.0	1.5	93

*Flange widths smaller than 4 inches will have a minimum radius of 137.8 inches.

**Flange widths smaller than 5 inches will have a minimum radius of 39.4 inches.

*** Although both 208/230 & 460 Volts are shown together, the dual speed motors are **NOT** reconnectable.

2.2 Dimensions

Table 2-2 Trolley Dimensions													
For NER2003L-FG to NER2020L-FG													
		Product Code	b	b'	d	e	e'	i	j	k	m	n	r
Single Speed	MR2010L/S-FG	12.4	15.6	8.7	20.3	7.1	3.74	0.9	5.1	8.1	4.3	2.0	1.22
	MR2020L/S-FG	12.8	16.4	8.9	20.5	7.2	4.33	1.1	4.9	8.4	4.7	2.4	1.42
Dual Speed	MR2010SD-FG	12.4	15.6	8.7	20.3	7.1	3.74	0.9	5.1	8.1	4.3	2.0	1.22
	MR2020SD-FG	12.8	16.4	8.9	20.5	7.2	4.33	1.1	4.9	8.4	4.7	2.4	1.42

6.2 Lubrication

- 6.1.1 Lubricate the following trolley components with only Nevastane HD2T White Drum food grade lubricating grease.
- 6.1.2 Track Wheel Gear – Clean and re-grease the Track Wheel gears and motor output pinion every three months (more frequently for heavier usage or severe conditions). Do not use an excessive amount of grease and avoid getting any grease on the running surfaces of the Track Wheels or the beam.
- 6.1.3 Gear Box – The reduction gearing in the motor should be cleaned and lubricated at least once per year for normal usage. Clean and lubricate the reduction gear assembly more frequently for heavier usage or severe conditions. Gain access to the gears by removing the four bolts that mount the motor assembly to the trolley Side Plate. Make sure to properly orient and reuse the neoprene gasket between the motor and Side Plate.
- 6.1.4 Suspension Pins, Bolts and Shafts – Grease at least twice per year for normal usage (more frequently for heavier usage or severe conditions).

IV TS2 Manual Trolley

Section	Page Number
1.0 Important Information and Warnings.....	TS2OM
1.1 Terms and Summary	
1.2 Warning Tags and Labels	
2.0 Technical Information	17
2.1 Specifications	
2.2 Dimensions	
2.3 Optional Equipment	
3.0 Pre-operational Procedures.....	TS2OM
3.1 Manual Hoist Adjustment for Trolley	
3.2 Electric Hoist Adjustment for Trolley	
3.3 Air Power Hoist Adjustment for Trolley	
3.4 Trolley Assembly	
3.5 Mounting Location	
3.6 Installation of Trolley onto Beam	
3.7 Electrical/Air Connections	
3.8 Pre-operational Checks and Trial Operation	
4.0 Operation.....	TS2OM
4.1 Introduction	
4.2 Shall's and Shall Not's for Operation	
4.3 Trolley Controls	
5.0 Inspection.....	TS2OM
5.1 General	
5.2 Inspection Classification	
5.3 Frequent Inspection	

Section	Page Number
5.4	Periodic Inspection
5.5	Occasionally Used Trolleys
5.6	Inspection Records
5.7	Inspection Methods and Criteria
6.0	Maintenance & Handling..... TS2OM
6.1	Lubrication.....19 and TS2OM
6.2	Storage
6.3	Outdoor Installation
7.0	Warranty.....TS2OM
8.0	Parts List..... 59
8.1	TS2 Push Trolley Parts – 1/4 to 2 Ton
8.2	TS2 Geared Trolley Parts – 1/4 to 2 Ton

2.1 Specifications

Product Code for TS2 Trolley Alone:

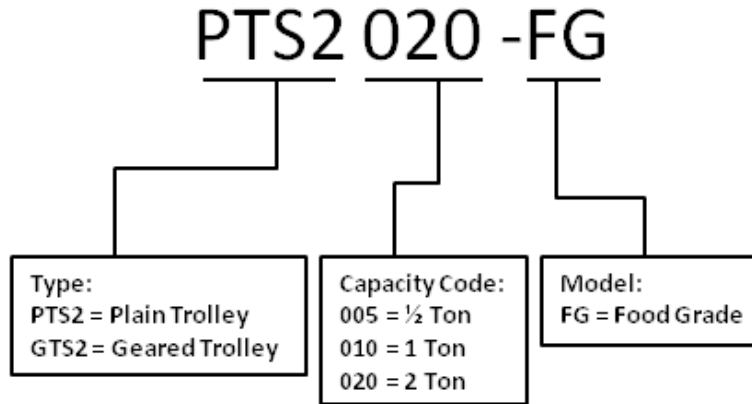

Operating Conditions and Environment

Temperature Range: -4° to +104°F (-20° to +40°C)

Humidity: 85% or less

Table 2-1 PTS2 Trolley Specifications					
Cap. (Tons)	Product Code	Min. Radius for Curve (in)	Flange Width Adjustability B (in)		Approx. Net Weight (lbs)
			Standard	Option	
1/2	PTS2005-FG	43.3	2.28 to 4.00	4.01 to 8.00 or 8.01 to 12.00	10
1	PTS2010-FG	51.2	2.28 to 5.00	5.01 to 8.00 or 8.01 to 12.00	18
2	PTS2020-FG	59.1	3.23 to 6.02	6.03 to 12.00	31

Table 2-2 GTS2 Trolley Specifications					
Cap. (Tons)	Product Code	Min. Radius for Curve (in)	Flange Width Adjustability B (in)		Approx. Net Weight (lbs)
			Standard	Option	
1	GTS2010-FG	51.2	2.28 to 5.00	5.01 to 8.00 or 8.01 to 12.00	27
2	GTS2020-FG	59.1	3.23 to 6.02	6.03 to 12.00	42

2.2 Dimensions

Table 2-3 PTS2 Trolley Dimensions

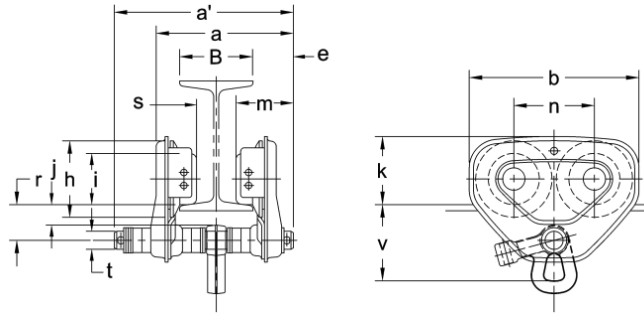

PTS2005 to PTS2020

Cap. (Tons)	Product Code	a max (in)	a' (in)	b (in)	e (ft)	h (in)	i (in)	j (in)	k (in)	m (in)	n (in)	r (in)	s (in)	t (in)	v (in)
1/2	PTS2005-FG	6.8	8.0	7.2	1.8	3.2	2.36	0.7	3.0	2.7	3.3	1.5	B-1.8	0.87	3.7
1	PTS2010-FG	8.5	9.8	9.3	2.2	4.2	2.80	1.1	3.7	3.1	4.4	2.0	B-1.9	0.98	4.2
2	PTS2020-FG	10.4	11.8	11.0	2.7	5.0	3.35	1.3	4.4	3.8	5.2	2.4	B-2.3	1.26	5.1

Table 2-4 GTS2 Trolley Dimensions

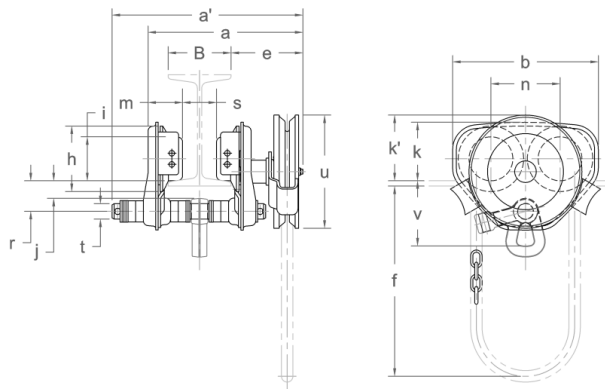

GTS2010 to GTS2020

Cap. (Tons)	Product Code	a max* (in)	a' max (in)	b (in)	e (in)	f (ft.)	h (in)	i (in)	j (in)	k (in)	k' (in)	m (in)	n (in)	r (in)	s (in)	t (in)	u (in)	v (in)
1/2-1	GTS2010-FG	10.8	13.6	9.3	6.0	10.5	4.2	2.80	1.1	3.7	4.2	2.2	4.4	2.0	B-1.8	0.98	7.2	4.2
2	GTS2020-FG	13.7	15.2	11.0	6.1		5.0	3.35	1.3	4.4	4.3	2.8	5.2	2.4	B-1.9	1.26		5.1

6.1 Lubrication

- 6.1.1 Lubricate the following trolley components with only Nevastane HD2T White Drum food grade lubricating grease.
- 6.1.2 Track Wheel Gear – Clean and re-grease the Track Wheel gears and Hand Wheel output pinion every three months (more frequently for heavier use). Do not use an excessive amount of grease and avoid getting any grease on the running surfaces of the Track Wheels or the beam.
- 6.1.3 Trolley Wheel Bearings do not need to be lubricated and must be replaced if worn or damaged.
- 6.1.4 Suspension Pins, Bolts, and Shafts – Grease at least twice per year for normal usage (more frequently for heavier usage or severe conditions).

This Page Intentionally Left Blank

V Parts List

1.0 NER2 Parts List

When ordering parts, please provide the hoist code number, lot number and serial number located on the hoist nameplate (see fig. below).

Reminder: To aid in ordering parts and product support, record the hoist code number, lot number and serial number in the space provided on the cover of this manual.

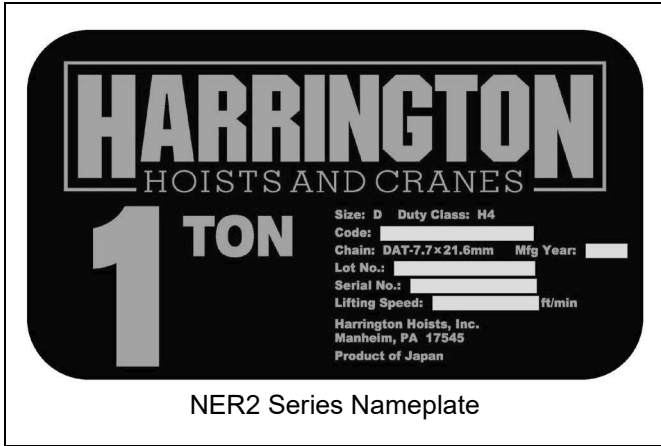

The parts list is arranged into the following sections:

Section	Page
1.1 Housing and Motor Parts.....	22
1.2 Gearing Parts.....	26
1.3 Hook and Chain Parts.....	30
1.4 Electric Parts (Single Speed).....	36
1.5 Electric Parts (Dual Speed).....	38
1.6 Power Supply and Pendant Parts.....	40

In the column "Parts Per Hoist" a designator is used for parts that apply only to a particular model or option. Refer to Chapter 2, Section 2 for hoist model numbers and additional descriptions. The designators are:

- S = Single Speed
- D = Dual Speed
- 2V = 208/230 Volt Models
- 4V = 460 Volt Models

1.1 Housing and Motor Parts

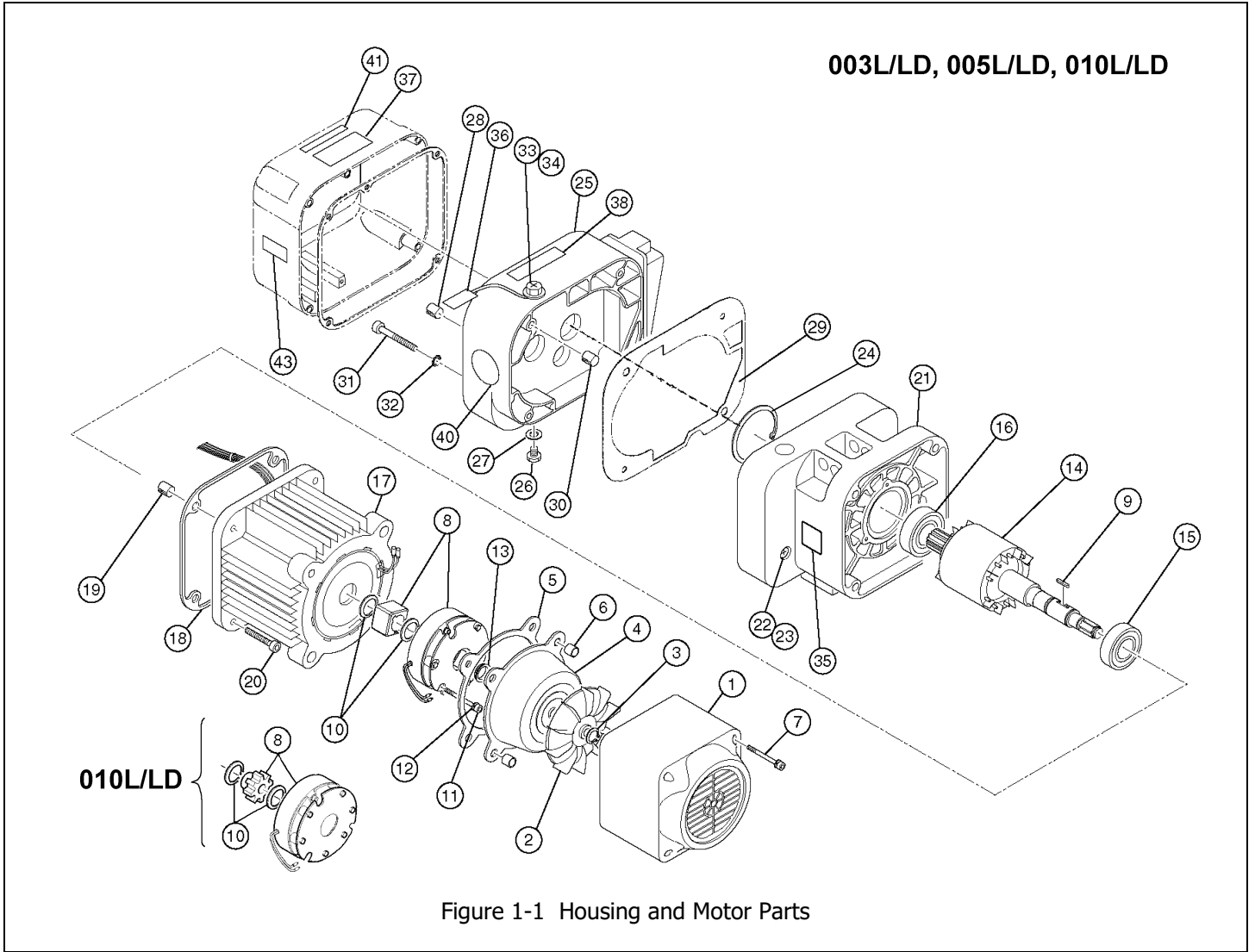

1.1 Housing and Motor Parts

Figure No.	Part Name	Parts Per Hoist	003L/LD	005L/LD	010L/LD
1	Fan Cover	1	2AFG005L9107		2AFG010L9107
2	Fan	1	ER2CL9108		ER2CS9108
3	Snap Ring	1	9047113		9047113
4	Brake Cover	1	ER2CL9115		ER2CS9115
5	Packing B	1	ER2CL9119		ER2CS9119
6	Set Pin S	2	ES120003		
7	Socket Bolt	4	J1BEE0504522		
8	Electromagnetic Brake Assembly	1	MBABB0ENA		MBABB09NA
9	Key B	1	ER2CL9360		ER2CS9360
10	Snap Ring	2	9047116		9047124
11	Socket Bolt	3	9091254		
12	Spring Lock Washer	3	J1WS01120060		
13	V Ring	1	ER2CS9210		ER2CS9210
14	Motor Shaft With Rotor	1	ER2CL5502		ER2DL5502
15	Ball Bearing	1	9000904		9000905
16	Ball Bearing	1	9000904		9000922
17	Motor Frame With Stator	1	3AFG005L5501		3AFG010L5501
18	Packing M	1	ER2CS9118		ER2DS9118
19	Set Pin S	2	ES120010S		ER1DS9138
20	Socket Bolt	4	J1BEE0803535		J1BEE1003535
21	Body B Assembly	1	3AFG005S6101		3AFG010S6101
22	Oil Plug	1	E3S111003		
23	Plug Packing	1	E3S112003		
24	Snap Ring	1	9047262		9047268
25	Gear Case	1	3AFG005S6103		3AFG010S6103
26	Oil Plug	1	E3S111003		
27	Plug Packing	1	E3S112003		
28	Spring Pin	1	E3S129005S		
29	Packing G	1	ER2CS9116		ER2DS9116
30	Set Pin S	2	ES120003		
31	Socket Bolt	4	9091262		
32	Toothed Lock Washer	4	9679709		
33	Oil Fill Plug	1	ER1BS9135		
34	Eyebolt Packing	1	ES127005S		
35	Name Plate Load Side E	1	ER1BS9960		
36	Oil Full Tag	1	ER1BS9953		
37	Warning Sticker E (Disconnect Power)	1	ER2CS9936		
38	Name Plate OF (Correct Oil Required)	1	2AFG003S9845		
40	Name Plate AD (Speed Letter)	1	ER1BL9868		ER1BL9868
41	Warning Sticker HW (Hot Surface)	D	ER2CI9806		
43	Check Voltage Label	S,2 V	ECP99NVVB		
		S,4 V	ECP99NVVA		
		D,2 V	ECP99NVWB		
		D,4 V	ECP99NVWA		

1.1 Housing and Motor Parts

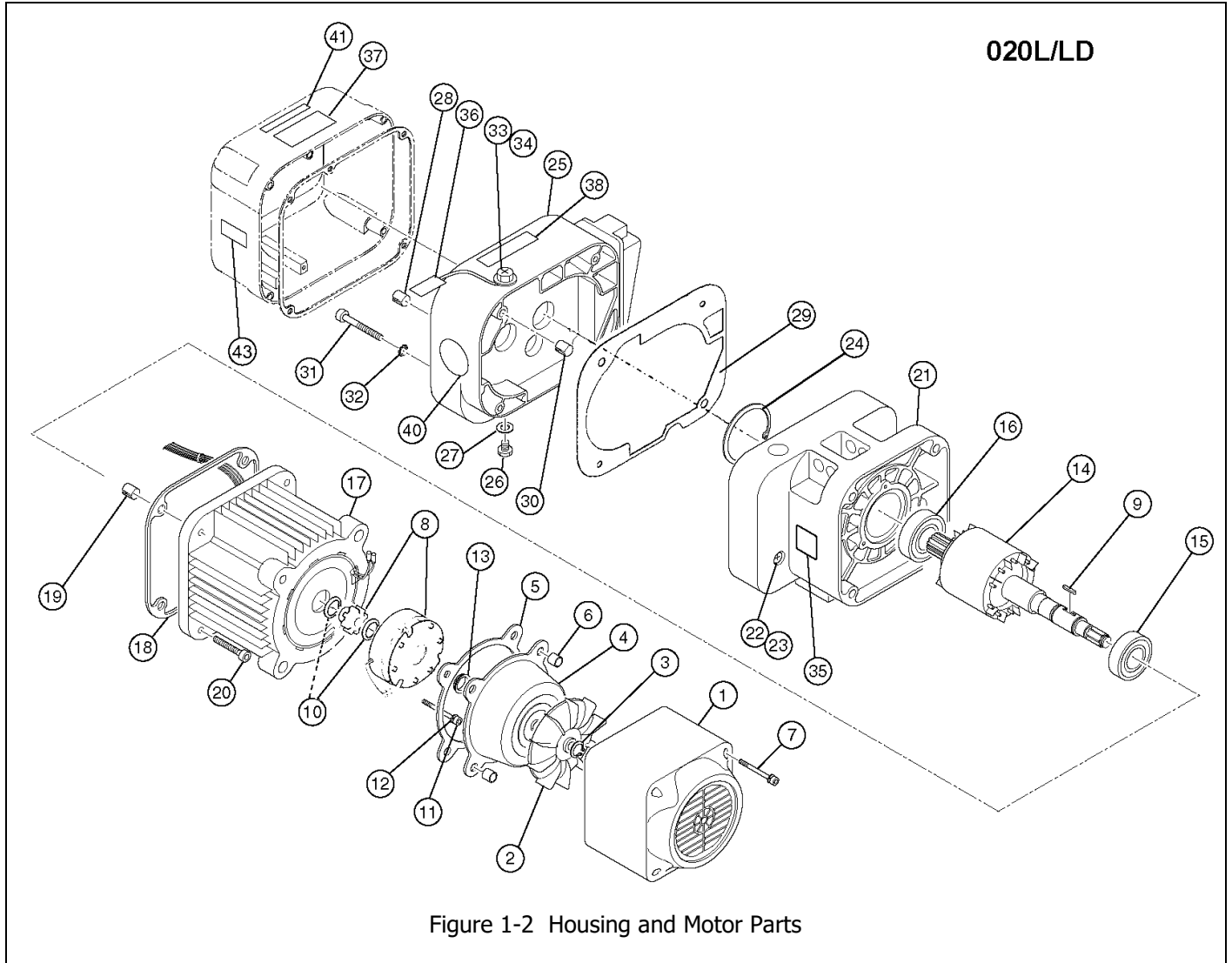

1.1 Housing and Motor Parts

Figure No.	Part Name	Parts Per Hoist	020L/LD	
1	Fan Cover	1	2AFG020L9107	
2	Fan	1	ER2DS9108	
3	Snap Ring	1	9047116	
4	Brake Cover	1	ER2DS9115	
5	Packing B	1	ER2DS9119	
6	Set Pin S	2	ES120003	
7	Socket Bolt	4	J1BEE0504522	
8	Electromagnetic Brake Assembly	1	MBABB18NA	
9	Key B	1	ER2DS9360	
10	Snap Ring	2	9047124	
11	Socket Bolt	3	9091254	
12	Spring Lock Washer	3	J1WS01120060	
13	V Ring	1	ER2DS9210	
14	Motor Shaft With Rotor	1	ER2EL5502	
15	Ball Bearing	1	9000905	
16	Ball Bearing	1	9000906	
17	Motor Frame With Stator	1	3AFG020L5501	
18	Packing M	1	ER2ES9118	
19	Set Pin S	2	ER2ES9138	
20	Socket Bolt	4	J1BEE1204040	
21	Body B Assembly	1	3AFG020S6101	
24	Snap Ring	1	9047280	
25	Gear Case	1	3AFG020L6103	
26	Oil Plug	1	E3S111003	
27	Plug Packing	1	E3S112003	
28	Spring Pin	1	E3S129005S	
29	Packing G	1	ER2ES9116	
30	Set Pin S	2	ES120010S	
31	Socket Bolt	4	9091286	
32	Toothed Lock Washer	4	9679711	
33	Oil Fill Plug	1	ER1BS9135	
34	Eyebolt Packing	1	ES127005S	
35	Name Plate Load Side E	1	ER1BS9960	
36	Oil Full Tag	1	ER1BS9953	
37	Warning Sticker E (Disconnect Power)	1	ER2CS9936	
38	Name Plate OF (Correct Oil Required)	1	2AFG003S9845	
40	Name Plate AD (Speed Letter)	1	ER1BL9868	
41	Warning Sticker HW (Hot Surface)	D	1	ER2CI9806
43	Check Voltage Label	S,2V	1	ECP99NVVB
		S,4V	1	ECP99NVVA
		D,2V	1	ECP99NVWB
		D,4V	1	ECP99NVWA

1.2 Gearing Parts

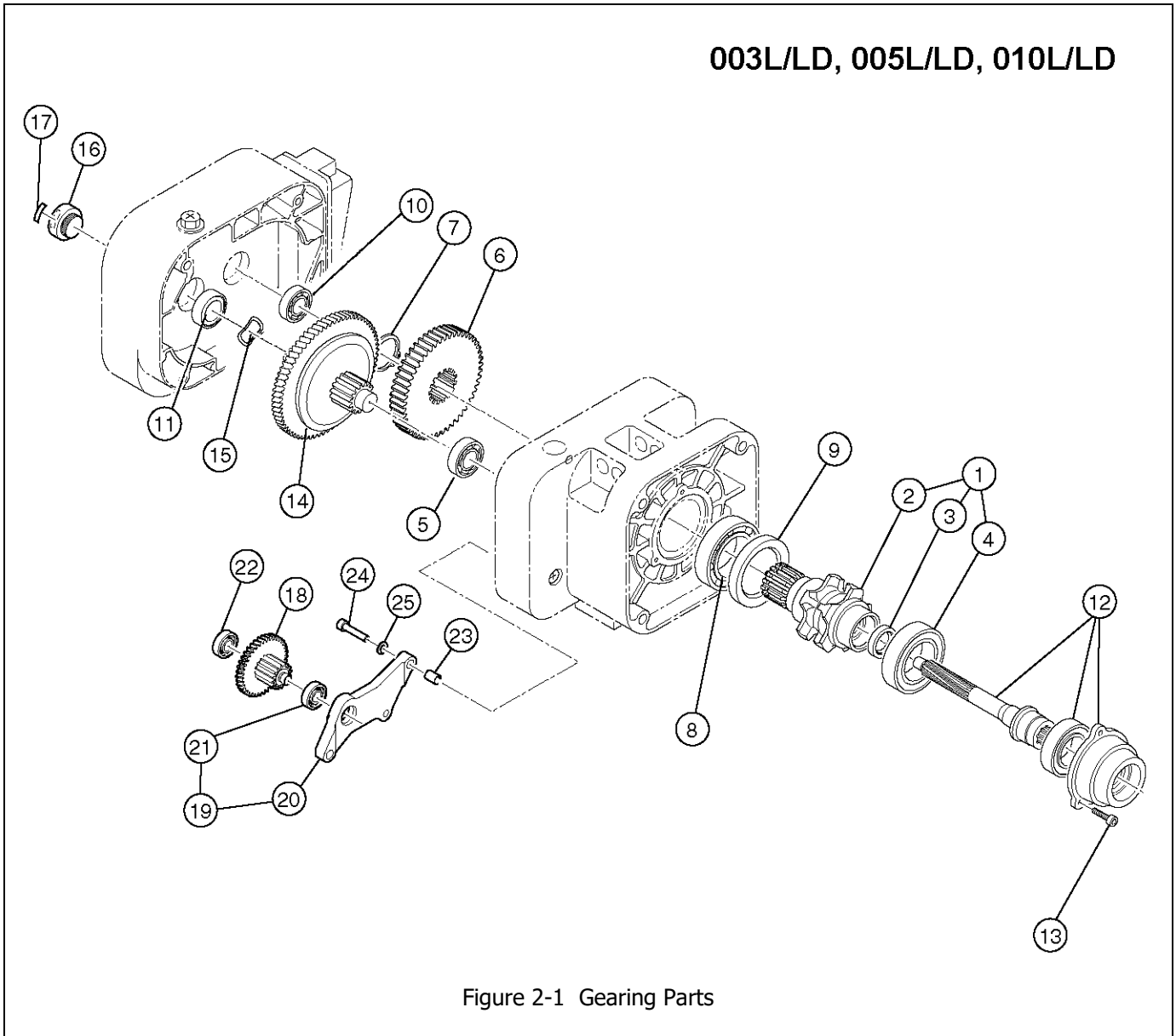

Figure 2-1 Gearing Parts

1.2 Gearing Parts

Figure No.	Part Name	Parts Per Hoist	003L/LD	005L/LD	010L/LD
1	Load Sheave Assembly	1	ER2CS6241		ER2DS6241
2	Load Sheave	1	ER2DS9241		ER2DS9241
3	Oil Seal	1	ES221010S		ES221010S
4	Ball Bearing	1	9000508		
5	Ball Bearing	1	9000302		9000304
6	Load Gear	1	ER2CL9240		ER2DS9240
7	Snap Ring	1	9047135		
8	Ball Bearing	1	9000107		9000108
9	Oil Seal	1	ES232005S		ES232010S
10	Ball Bearing	1	9000201		9000301
11	Oil Seal	1	E6F235003S		
12	Pinion Assembly	1	ER2CS5220		ER2DS5220
13	Socket Bolt	3	90912149		
14	Friction Clutch Complete Assembly	1	ER2CL1223		ER2DL1223
15	Wave Washer	1	E1DBX20S9311		
16	Nut Cover	1	ER1CS9235		
17	Name Plate FP (Adjustment Of Friction Clutch Prohibited)	1	ER1BS9892		
18	Gear B Assembly	1			ER2DL5262
19	Gear Holder Plate Assembly	1			ER2DL6261
20	Gear Holder Plate	1			ER2DL9261
21	Ball Bearing	1			9000101
22	Ball Bearing	1			9000100
23	Set Pin S	2			ES120003
24	Socket Bolt	3			9091252
25	Spring Lock Washer	3			9012709

1.2 Gearing Parts

020L/LD

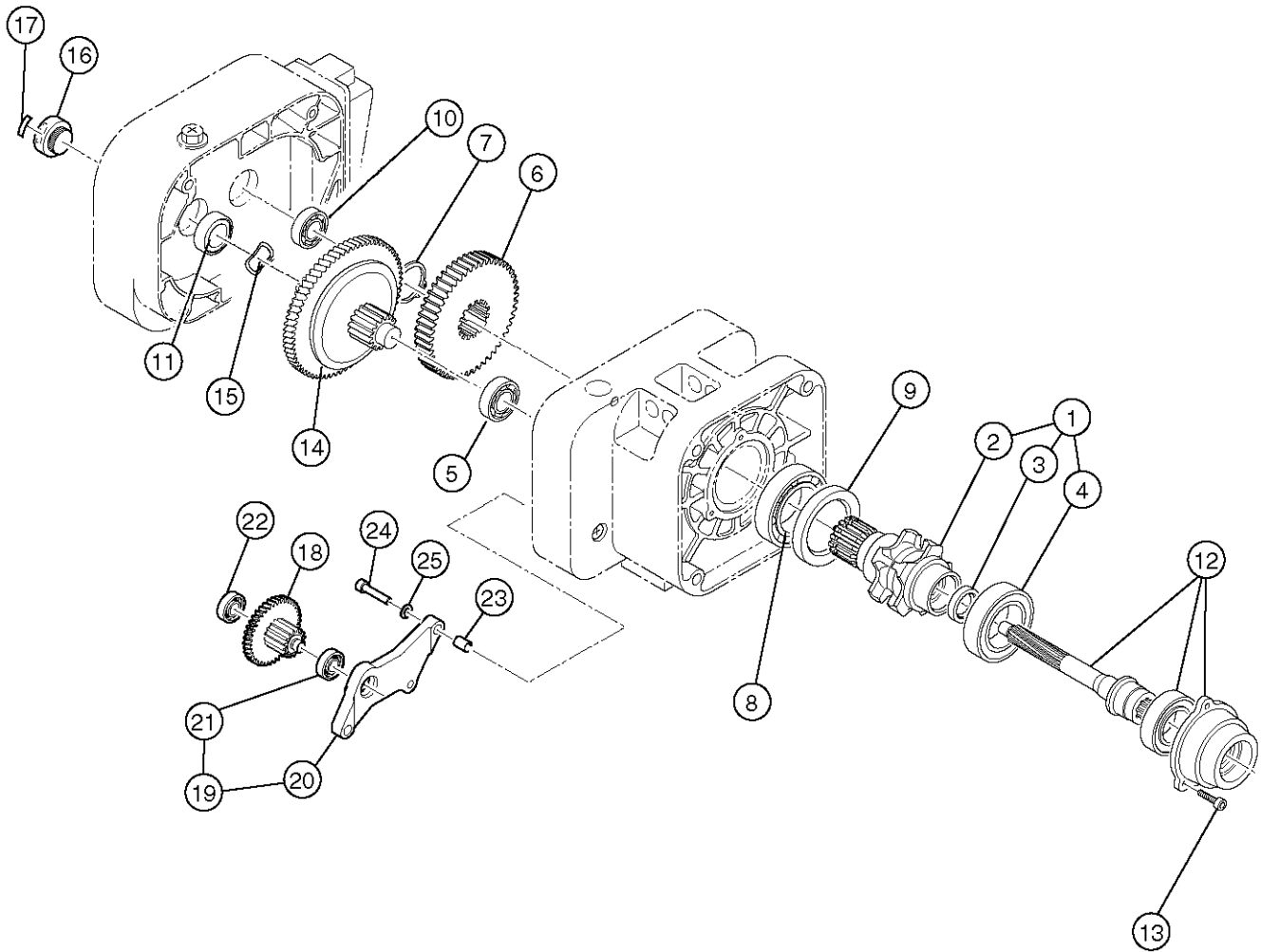
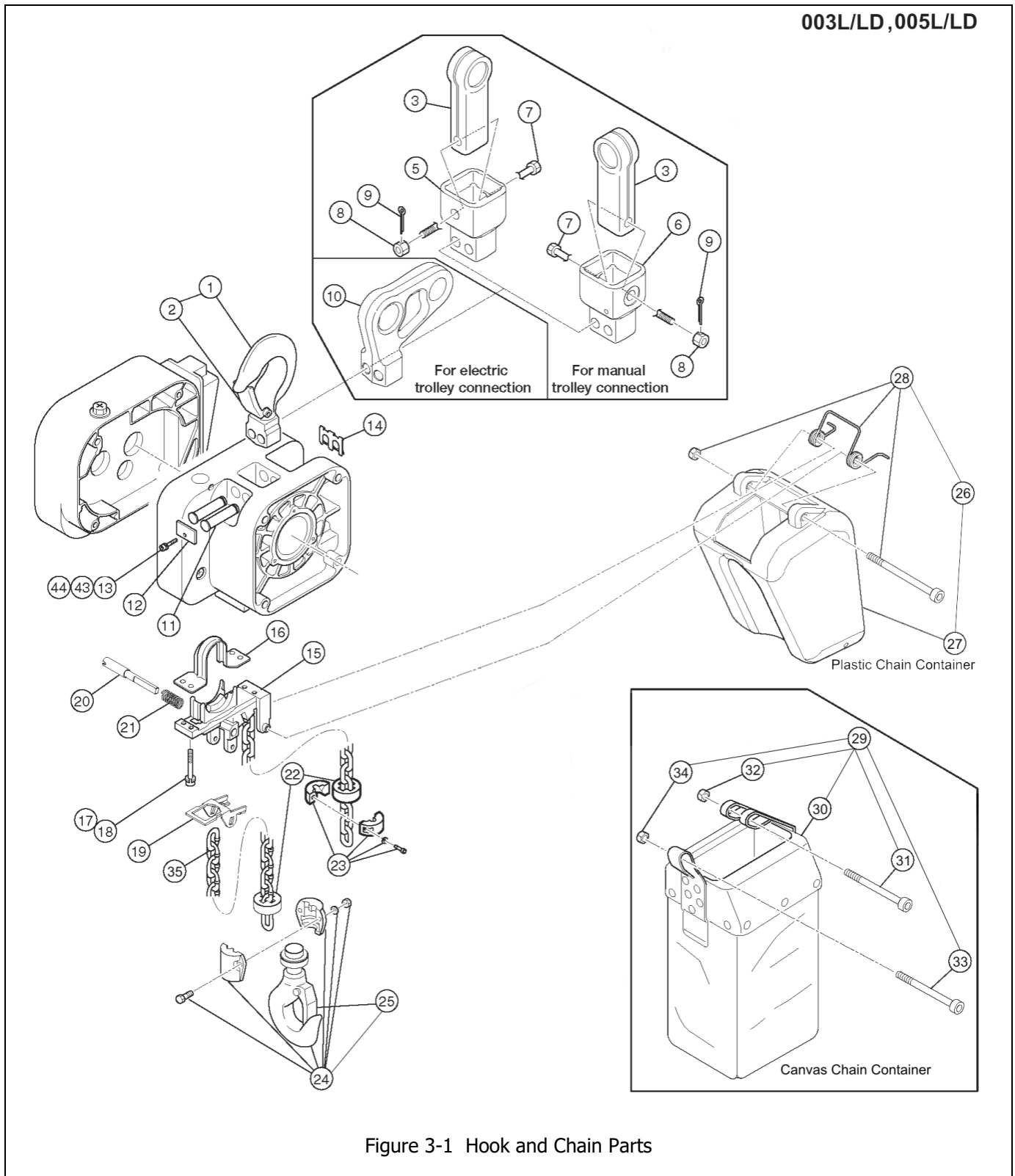

Figure 2-2 Gearing Parts

1.2 Gearing Parts

Figure No.	Part Name	Parts Per Hoist	020L/LD
1	Load Sheave Assembly	1	ER2ES6241
2	Load Sheave	1	ER2ES9241
3	Oil Seal	1	ER2ES9221
4	Ball Bearing	1	9000609
5	Ball Bearing	1	9000405
6	Load Gear	1	ER2EL9240
7	Snap Ring	1	9047150
8	Ball Bearing	1	9000110
9	Oil Seal	1	ER2ES9244
10	Ball Bearing	1	9000303
11	Oil Seal 22	1	ER1DS9233
12	Pinion Assembly	1	ER2EL5220
13	Socket Bolt	3	90912149
14	Friction Clutch Complete Assembly	1	ER2EL1223
15	Wave Washer	1	ER1DS9234
16	Nut Cover	1	ER1DS9235
17	Name Plate FP (Adjustment Of Friction Clutch Prohibited)	1	ER1BS9892
18	Gear B Assembly	1	ER2EL5262
19	Gear Holder Plate Assembly	1	ER2EL6261
20	Gear Holder Plate	1	ER2EL9261
21	Ball Bearing	1	9000202
22	Ball Bearing	1	9000201
23	Set Pin S	2	ES120010S
24	Socket Bolt	3	9091275
25	Spring Lock Washer	3	9012711

1.3 Hook and Chain Parts



*Optional stainless steel chain container assembly not shown. See Figure No. 45 on part number chart for ordering information.

1.3 Hook and Chain Parts

Figure No.	Part Name	Parts Per Hoist	003L/LD	005L/LD
1	Top Hook Assembly	1	2ASF005S5101	
2	Hook Latch	1	2ASF003S1103	
3	Suspender E (For Push Trolley) – White Epoxy Paint	1	36FG0059004	
	Suspender E (For Push Trolley) – Nickel Plated		37FG0059004	
	Suspender E (For Geared Trolley) – White Epoxy Paint		36FG0109004	
	Suspender E (For Geared Trolley) – Nickel Plated		37FG0109004	
5	Connection Yoke P (For Push Trolley) – White Epoxy Paint	1	2AFG005S9027	
6	Connection Yoke G (For Geared Trolley) – White Epoxy Paint	1	2AFG005S9029	
7	Yoke Bolt	1	2AFG005S9032	
8	Slotted Nut	1	J1NL00910100	
9	Split Pin	1	J1PW06025018	
10	Suspender T (For Motorized Trolley) – White Epoxy Paint	1	2AFG010S9031	
	Suspender T (For Motorized Trolley) – Nickel Plated		2AFG010S9831	
11	Top Pin	2	WR2CS9121	
12	Plate A	1	ER2CS9123	
13	Socket Bolt	1	J1BEE0601414	
14	Shaft Clip	1	ER2CS9186	
15	Chain Guide A	1	ER2CS9331	
16	Chain Guide B	1	ER2CS9332	
17	Socket Bolt	4	J1BEE0602525	
18	Spring Lock Washer	4	J1WS07420060	
19	Limit Lever	1	ER2CS9337	
20	Limit Lever Pin	1	ER2CS9338	
21	Limit Lever Spring	1	WR2CS9357	
22	Cushion Rubber – Standard	2	ER1CS9053	
	Cushion Rubber – Stainless Steel	2	275F005S9117	
23	Stopper Assembly – Standard	1	ER1CS1041	
	Stopper Assembly – Nickel Plated		2AFG005S1041	
24	Bottom Hook Complete Assembly – White Epoxy Paint	1	2AFG003H1011	2AFG005S1011
	Bottom Hook Complete Assembly – Stainless Steel		2ASF003H5211	2ASF005S5211
25	Hook Latch - Epoxy	1	2ASF003S1103	
	Hook Latch – Stainless Steel	1	2AFG010S2103*	
26	Plastic Chain Container Assembly (Max. Lifting Height 20ft)	1	PBK2-C-FG	
27	Plastic Chain Container	1	ER2CS1401	
28	Plastic Container Spring Assembly	1	2AFG005S1416	
29	Canvas Chain Container Assembly (Max. Lift Height 50ft)	1	BK2C2-FG	
30	Canvas Chain Container	1	ER2CS5405	
31	Socket Bolt	1	J1BEB0807528	
32	Lever Nut	1	J1NU00920080	
33	Socket Bolt	1	J1BEB0604508	
34	Lever Nut	1	J1NU00920080	
35	NP Load Chain	1	LCER2005NP-FG	
35	ND Load Chain	1	LCER2005ND-FG	
43	Washer	1	J1WB07420060	
44	Spring Lock Washer	1	J1WS07420060	
45	Stainless Steel Chain Container Assembly – maximum 23 ft. lift	1	7042201	
	Stainless Steel Chain Container Assembly – maximum 49 ft. lift		7042202	

*Note: Stainless Steel Hook Latch P/N is for units sold **AFTER** 2016. If you have a previous version, please consult with Customer Service.

1.3 Hook and Chain Parts

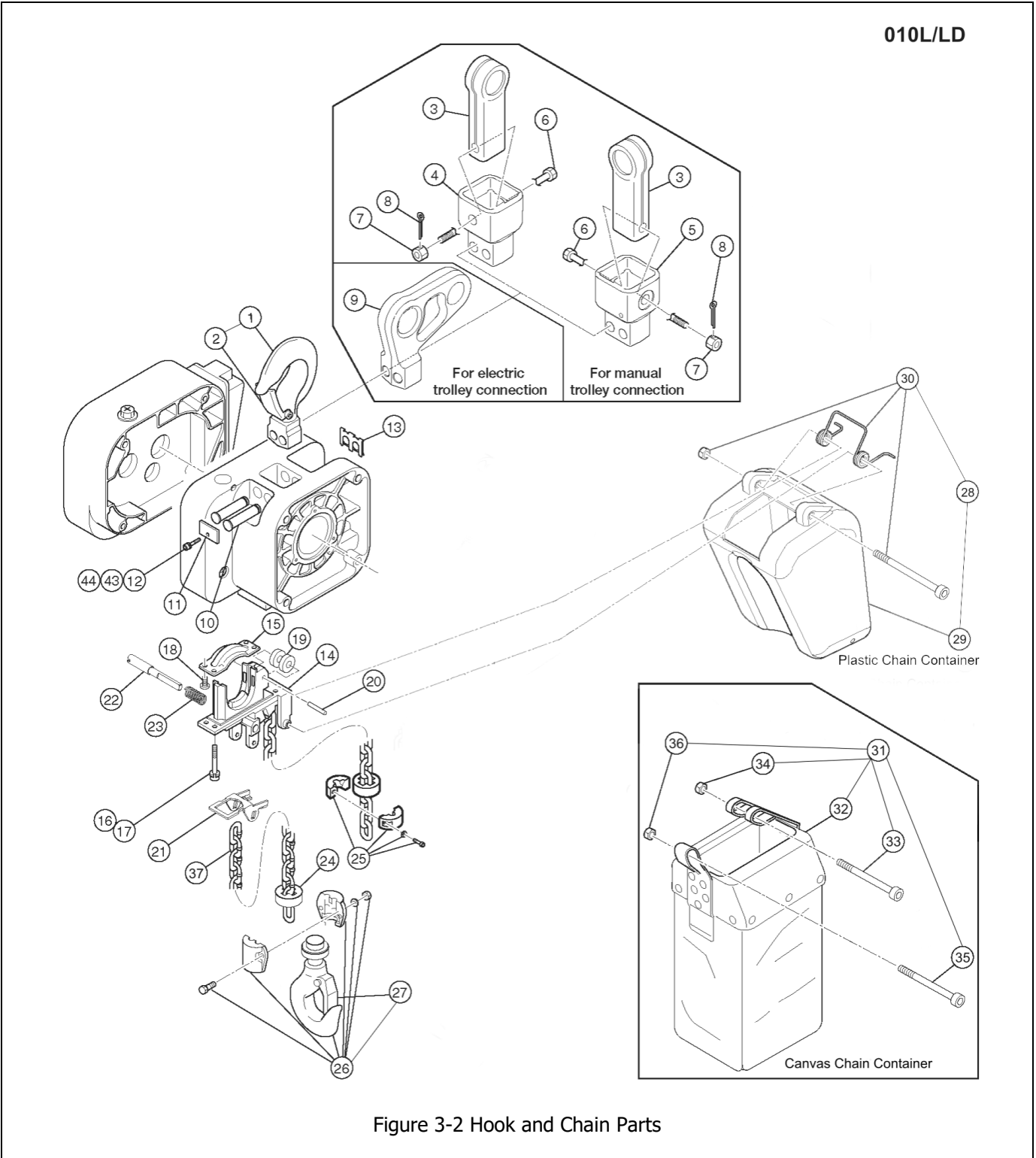

*Optional stainless steel chain container assembly not shown. See Figure No. 45 on part number chart for ordering information.

1.3 Hook and Chain Parts

Figure No.	Part Name	Parts Per Hoist	O10L
1	Top Hook Assembly	1	2ASF010S5101
2	Hook Latch	1	2AFG010S2103
3	Suspender E (For Manual Trolley) – White Epoxy Paint	1	36FG0109004
	Suspender E (For Manual Trolley) – Nickel Plated		37FG0109004
4	Connection Yoke P (For Push Trolley) – White Epoxy Paint	1	2AFG005S9027
5	Connection Yoke G (For Geared Trolley) – White Epoxy Paint	1	2AFG005S9029
6	Yoke Bolt	1	2AFG005S9032
7	Slotted Nut	1	J1NL00910100
8	Split Pin	1	J1PW06025018
9	Suspender T (For Motorized Trolley) – White Epoxy Paint	1	2AFG010S9031
	Suspender T (For Motorized Trolley) – Nickel Plated		2AFG010S9831
10	Top Pin	2	WR2CS9121
11	Plate A	1	ER2CS9123
12	Socket Bolt	1	J1BEE0601414
13	Shaft Clip	1	ER2CS9186
14	Chain Guide A	1	ER2DS9331
15	Chain Guide B	1	ER2DS9332
16	Socket Bolt	4	J1BEE0802525
17	Spring Lock Washer	4	J1WS07420080
18	Machine Screw With Spring Washer	4	J1AP45001212
19	Guide Roller	1	ER2DS9333
20	Roller Pin	1	ER1CS9334
21	Limit Lever	1	ER2DS9337
22	Limit Lever Pin	1	ER2DS9338
23	Limit Lever Spring	1	WR2CS9357
24	Cushion Rubber – Standard	2	ER1DS9053
	Cushion Rubber – Stainless Steel	2	27SF010S9117
25	Stopper Assembly – Standard	1	ER1DS1041
	Stopper Assembly – Nickel Plated		2AFG010S1041
26	Bottom Hook Complete Assembly – White Epoxy Paint	1	2AFG010S1011
	Bottom Hook Complete Assembly – Stainless Steel		2ASF010S5211
27	Hook Latch - Epoxy	1	2AFG010S2103
	Hook Latch – Stainless Steel	1	2ASF010S1103
28	Plastic Chain Container Assembly (Max. Lifting Height 20ft)	1	PBK2-D-FG
29	Plastic Chain Container	1	ER2DS1401
30	Plastic Container Spring Assembly	1	2AFG010S1416
31	Canvas Chain Container Assembly (Max. Lifting Height 50ft)	1	BK2D2-FG
32	Canvas Chain Container	1	ER2DS5405
33	Socket Bolt	1	J1BEB0809028
34	Lever Nut	1	J1NU00920080
35	Socket Bolt	1	J1BEB0604508
36	Lever Nut	1	J1NU00920060
37	NP Load Chain	1	LCER2010NP-FG
37	ND Load Chain	1	LCER2010ND-FG
43	Washer	1	J1WB07420060
44	Spring Lock Washer	1	J1WS07420060
45	Stainless Steel Chain Container Assembly – maximum 26 ft. lift	1	7042203
	Stainless Steel Chain Container Assembly – maximum 49 ft. lift		7042205

1.3 Hook and Chain Parts

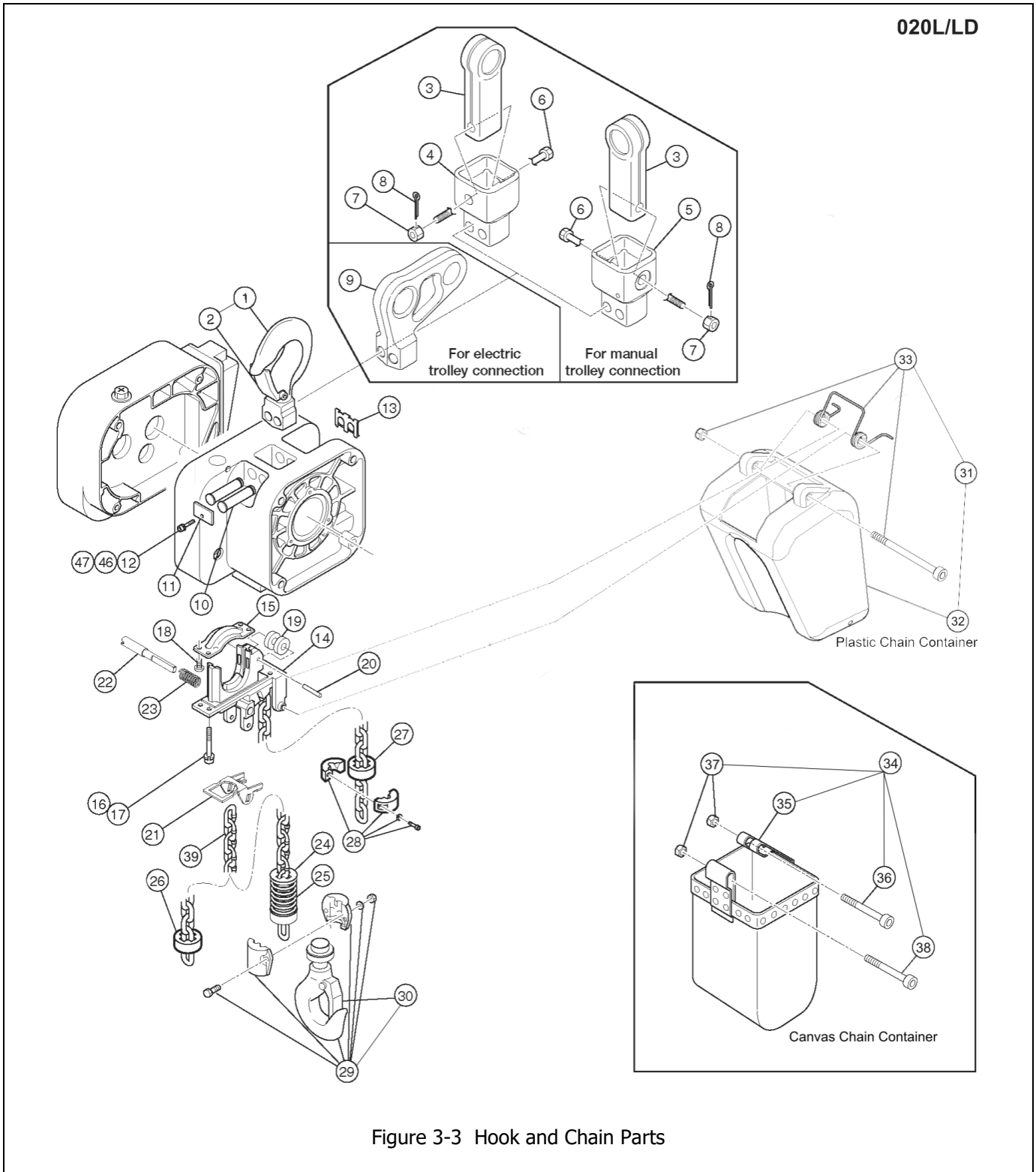

Figure 3-3 Hook and Chain Parts

*Optional stainless steel chain container assembly not shown. See Figure No. 45 on part number chart for ordering information.

1.3 Hook and Chain Parts

Figure No.	Part Name	Parts Per Hoist	020L
1	Top Hook Assembly	1	2ASF020S5101
2	Hook Latch	1	2AFG020S2103
3	Suspender E (For Manual Trolley) – White Epoxy paint	1	36FG0209004
	Suspender E (For Manual Trolley) – Nickel Plated		37FG0209004
4	Connection Yoke P (For Push Trolley) – White Epoxy Paint	1	2AFG020S9027
5	Connection Yoke G (For Geared Trolley) – White Epoxy Paint	1	2AFG020S9029
6	Yoke Bolt	1	2AFG020S9032
7	Slotted Nut	1	J1NL00920160
8	Split Pin	1	J1PW06040030
9	Suspender T (For Motorized Trolley) – White Epoxy Paint	1	2AFG020S9031
	Suspender T (For Motorized Trolley) – Nickel Plated		2AFG020S9831
10	Top Pin	2	2AFG020S9121
11	Plate A	1	ER2ES9123
12	Socket Bolt	1	J1BEE0601414
13	Shaft Clip	1	ER2ES9186
14	Chain Guide A	1	ER2ES9331
15	Chain Guide B	1	ER2ES9332
16	Socket Bolt	4	J1BEE0803030
17	Spring Lock Washer	4	J1WS07420080
18	Machine Screw With Spring Washer	4	J1AP46001212
19	Guide Roller	1	ER1DL9333
20	Roller Pin	1	ER1DL9334
21	Limit Lever	1	ER2ES9337
22	Limit Lever Pin	1	ER2EL9338
23	Limit Lever Spring	1	WR2CS9357
24	Limiting Plate – Standard	1	ER1ES9054
	Limiting Plate – Stainless Steel		27SF020S9118
25	Chain Spring – Standard	1	ER1DL9051
	Chain Spring – Stainless Steel		2AFG020L9112
27	Cushion Rubber – Standard	1	ER1ES9053
	Cushion Rubber – Stainless Steel		27SF020S9117
28	Stopper Assembly – Standard	1	ER1ES1041
	Stopper Assembly – Nickel Plated		2AFG020S1041
29	Bottom Hook Complete Assembly – White Epoxy Paint	1	2AFG020S1011
	Bottom Hook Complete Assembly – Stainless Steel		2ASF020S5211
30	Hook Latch - Epoxy	1	2AFG020S2103
	Hook Latch – Stainless Steel	1	2ASF020S1103*
31	Plastic Chain Container Assembly (Max. Lifting Height 13ft)	1	PBK2-E-FG
32	Plastic Chain Container	1	ER2ES1401
33	Plastic Container Spring Assembly	1	2AFG020S1416
34	Canvas Chain Container Assembly (Max. Lifting Height 60ft)	1	BK2E2-FG
35	Canvas Chain Container	1	ER2ES5405
36	Socket Bolt	1	J1BEB1010032
37	Lever Nut	2	J1NU00920100
38	Socket Bolt	1	J1BEB1007532
39	NP Load Chain	1	LCER2020NP-FG
39	ND Load Chain	1	LCER2020ND-FG
45	Stainless Steel Chain Container Assembly – maximum 20 ft. lift	1	7042204
	Stainless Steel Chain Container Assembly – maximum 39 ft. lift		7042206
46	Washer	1	J1WB07420060
47	Spring Lock Washer	1	J1WS07420060

*Note: Stainless Steel Hook Latch P/N is for units sold **AFTER** 2016. If you have a previous version, please consult with Customer Service.

1.4 Electric Parts (Single Speed)

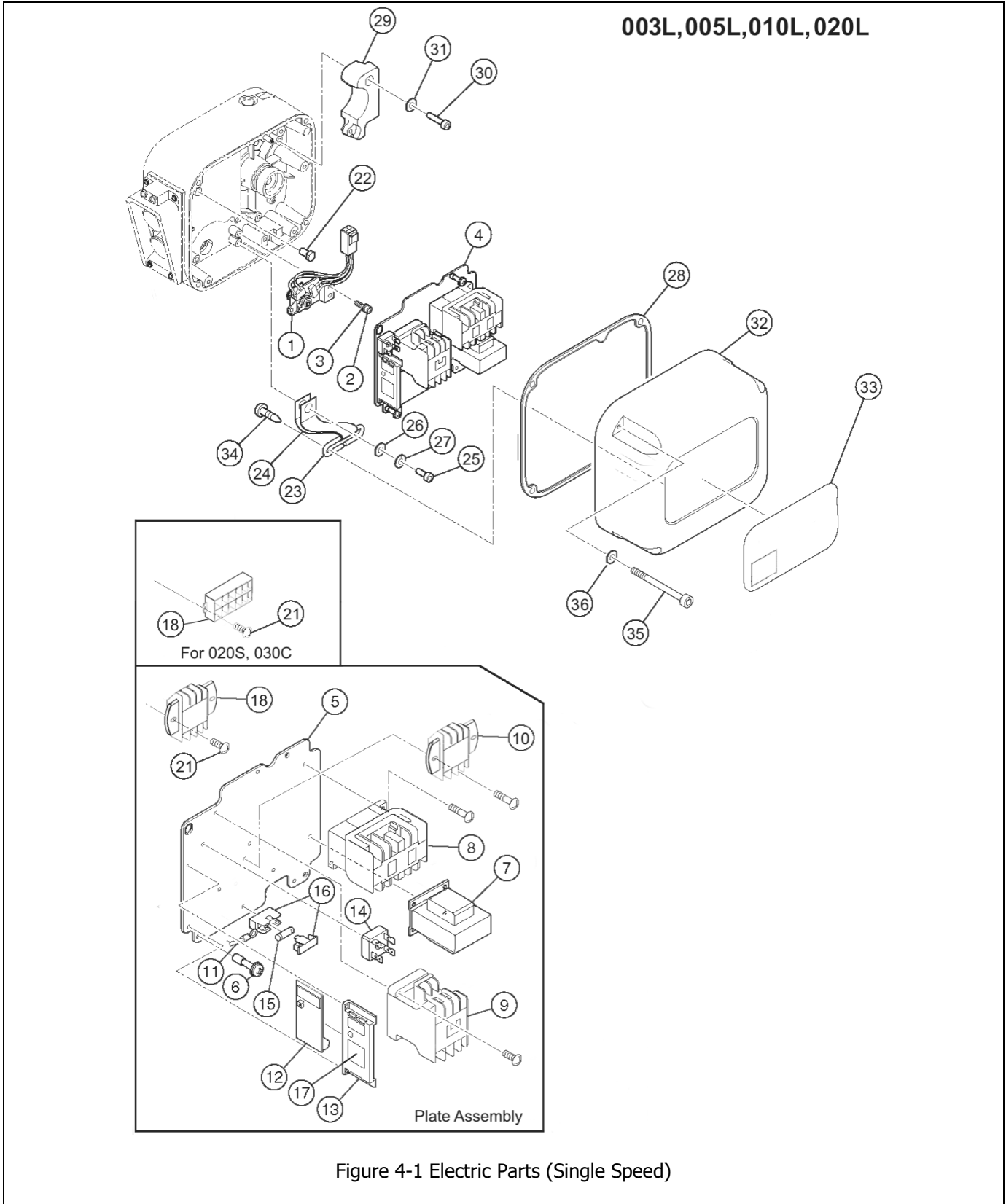

1.4 Electric Parts (Single Speed)

Figure No.	Part Name	Parts Per Hoist	003L	005L	010L	020L
1	Limit Switch Complete Assembly	1	ER2C11060			
2	Socket Bolt	3	9091247			
3	Spring Lock Washer	3	9012709			
4	Plate Assembly	1	ER2GHM05L5A2	ER2GHM10S5A2	ER2GHM20L5A2	
5	Plate	1	ER2CS9441	ER2DS9441	ER2ES9441	
6	Plate Screw	3	ER1BS9445			
7	Transformer	1	TRF72V611	TRF73V611		
8	Electromagnetic Contactor	1	MGC23406C	MGC23406A		
9	E-Stop Contactor	1	MGC13306F**			
			MGC14306C**			
10	Terminal Block 3P	1	ECP1303AB		ECP1303AB	
	Terminal Block 9P			ECP1309AB		
11	Lead Wire	1	ER2GHM05L9A2	ER2GHM05S9A2	ER2GHM20S9A2	
12	CH Meter	1	ECP91CHAE			
13	CH Meter Support	1	ECP99BKBA			
14	Rectifier	1	ECP93DIAA			ECP94DIAA
15	Fuse	1	9006275			
16	Fuse Holder	1	ECP92FZAA			
17	Name Plate CH	1	ECP99CHAA			
18	Terminal Block 6P	1	ECP1306AD		ECP1306AD	
22	Fulcrum Pin	1	ER2CS9449			
23	Cover Suspender	1	ER2CS9456			
24	Cover Belt	1	ER2CS9457			
25	Socket Bolt	1	9091249			
26	Plain Washer	1	ER1BS9436			
27	Spring Lock Washer	1	9012709			
28	Packing C	1	ER2CS9117	ER2DS9117	ER2ES9117	
32	Controller Cover	F 1	2AFG005S9104	2AFG010S9104	2AFG020S9104	
33	Name Plate B	1	ER2BHM05S9A5	ER2BHM10S9A5	ER2BHM20S9A5	
34	Pan Head Mach. Screw	2	9798534			
35	Socket Bolt	4	J1BEE0504022	J1BEE0604024		
36	Washer	1	J1WB07420050	J1WB07420060		

**Refer to the alpha-numeric code on contactor. The code "S-U12" corresponds to MGD13306F. The code "S-N11" corresponds to MGC13306H. The code "CLK-25J3" corresponds to MGC14306C.

1.5 Electric Parts (Dual Speed)

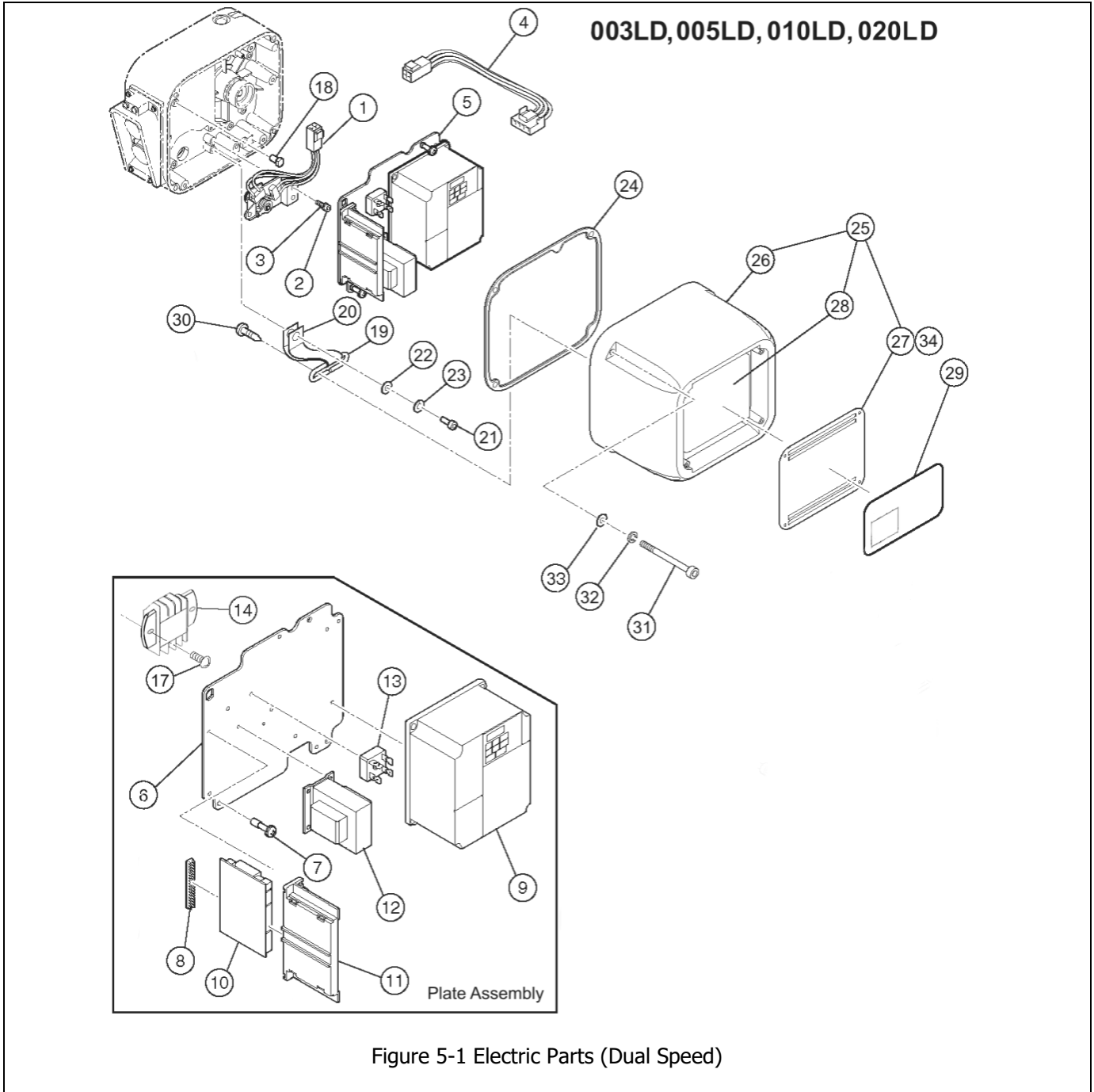

1.5 Electric Parts (Dual Speed)

Figure No.	Part Name	Parts Per Hoist	005LD	010LD	020LD	
1	Limit Switch Complete Assembly	1	ER2CI1060			
2	Socket Bolt	3	9091247			
3	Spring Lock Washer	3	9012709			
4	LS Harness	1	ER2CI9554			
5	Plate Assembly	M, 2V	1	ER2LHE05J5A2	ER2LHE10J5A2	ER2LHE20J5A2
		F, 2V	1	ER2BHE05J5A2	ER2BHE10J5A2	ER2BHE20J5A2
		M, 4V	1	ER2LHN05J5A2	ER2LHN10J5A2	ER2LHN20J5A2
		F, 4V	1	ER2BHN05J5A2	ER2BHN10J5A2	ER2BHN20J5A2
6	Plate	1	ER2CI9441	ER2DI9441	ER2EI9441	
7	Plate Screw	3	ER1BS9445			
8	Bushing	1	ECP99JBAC			
9	Inverter Assembly	M, 2V	1	INV60FH24	INV615H24	INV622H24
		F, 2V	1	INV60FH21	INV615H21	INV622H21
		M, 4V	1	INV60FM24	INV615M24	INV622M24
		F, 4V	1	INV60FM21	INV615M21	INV622M21
10	Interface Board	1	ECP91KB02			
11	Board Support	1	ECP99BKAA			
12	Transformer	2V	1	TRF32C612		
		4V	1	TRF32N612		
13	Rectifier	1	ECP93DIAA			
14	Terminal Block 6P	1	ECP1306AD			
17	Machine Screw	2	9798512			
18	Fulcrum Pin	1	ER2CS9449			
19	Cover Suspender	1	ER2CS9456			
20	Cover Belt	1	ER2CS9457			
21	Socket Bolt	1	9091249			
22	Plain Washer	1	ER1BS9436			
23	Spring Lock Washer	1	9012709			
24	Packing C	1	ER2CS9117	ER2DS9117	ER2ES9117	
25	Controller Cover Assembly	2V	1	2AFG005I2104	2AFG010I2104	2AFG020I2104
		4V	1	2AFG005I1104	2AFG010I1104	2AFG020I1104
26	Controller Cover	1	2AFG005I9104	2AFG010I9104	2AFG020I9104	
27	Resistor Cover	1	2AFG005I9185	2AFG010I9185	2AFG020I9185	
28	Braking Resistor	2V	1	INV70EE16	INV718E16	INV718E16
		4V	1	INV70EY16	INV718Y16	INV718Y16
34	Mach. Screw w/Spring Washer	4	JAW44001212			
29	Name Plate B	1	ER2BHM05I9A5	ER2BHM10I9A5	ER2BHM20I9A5	
30	Pan Head Machine Screw	2	9798534			
31	Socket Bolt	4	J1BEE0504022	J1BEE0604024		
32	Toothed Lock Washer	4	J1WS07420050	J1WS07420060		
33	Washer	4	J1WB07420050	J1WB07420060		

1.6 Power Supply and Pendant Parts

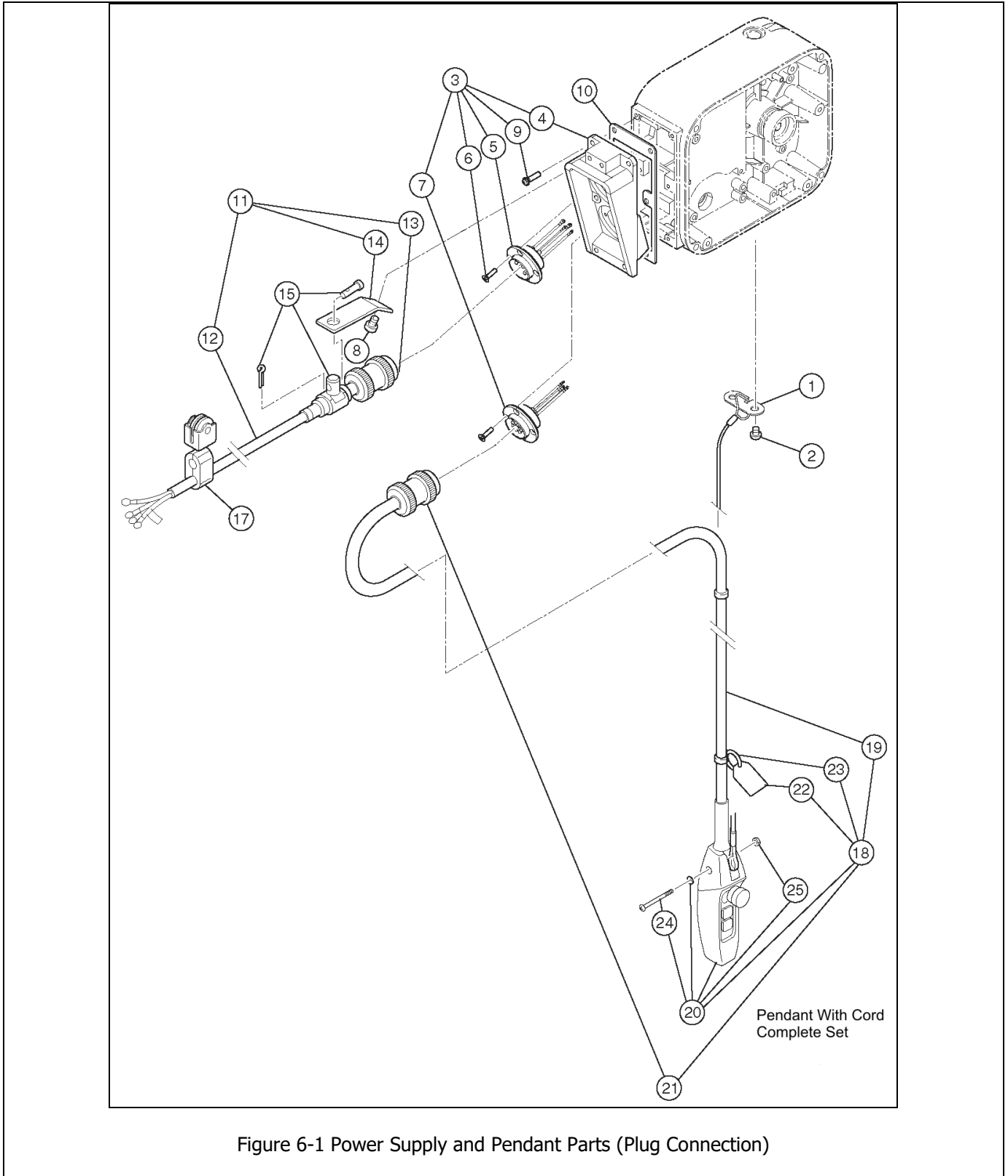

Figure 6-1 Power Supply and Pendant Parts (Plug Connection)

1.6 Power Supply and Pendant Parts

Figure No.	Part Name	Parts Per Hoist	005L/LD	010L/LD	020L/LD
1	Cord Support (Wire Stop)	1	ER1BS9534		
2	Mach. Screw W/Spring Washer	2	J1AP45001212		
3	Socket Frame Complete Assembly	S	2AFG005S4511		2AFG020S4511
		D	2AFG005I4511	2AFG010I4511	2AFG020I4511
4	Socket Frame	1	2AFG005S9511		
5	Socket 4P Assembly	S	ER2CS2523		ER2ES2523
		D	ER2CI2523	ER2CS2523	ER2EI2523
6	Tapping Flat Head Mach. Screw	8	ES558003		
7	Socket 8P Assembly	S	ER2CS2564		
		D	ER2CI2564		ER2EI2564
8	Mach. Screw W/Spring Washer	2	ES650005S		
9	Mach. Screw W/ Spring Washer	6	J1AP45002020		
10	Socket Frame Packing	1	ER2CS9512		
11	Power Supply Cable 4C Assembly	1	ZBZA12CH1000		
12	Power Supply Cable 4C	ft	16/4		
13	Plug 4P	1	ECP2304AD		
14	Cable Support Arm	1	ER1BS9541		
15	Cable Support 12 Assembly	1	ES822003		
17	Cable Hanger 14 Assembly	A/R	ES1527003		
18	Pendant W/Cord Complete Assembly	S	ZB10025H1000		
		D	ZB20025I1000		
19	Pendant Cord	S	16/4P		
		D	16/6P		
20	Pendant Assembly	S	SWD1100AAH		
		D	SWD2200AAH		
21	Plug 8P	S	ECP2108AA		
		D	ECP2108AB		
22	Warning Tag PB	1	WTAG7		
23	Tag Holder	1	E3S787003		
24	Machine Screw	1	J1AP24002608		
25	Nut	1	9093414		

Note: A/R = As required, one every 5 ft. of Power Supply Cable.

This Page Intentionally Left Blank

2.0 MR2 Parts List

When ordering parts, please provide the trolley code number, lot number and serial number located on the hoist nameplate (see fig. below).

Reminder: To aid in ordering parts and product support, record the trolley code number, lot number and serial number in the space provided on the cover of this manual.



The parts list is arranged into the following sections:

	Page
Section 1/4 to 2 Ton	
2.1 Electric Parts – 1/4 to 2 Ton.....	44
2.2 Pendant Parts – 1/4 to 2 Ton	48
2.3 Power Supply Parts – 1/4 to 2 Ton	50
2.4 Side Plates and Suspension Parts – 1/4 to 2 Ton	52
2.5 Motor Parts – 1/4 to 2 Ton	54

In the column "Parts Per Trolley" a designator is used for parts that apply only to a particular model or option. Refer to Chapter 3, Section 2 for MR2 trolley model numbers and additional descriptions.

The designators are:

- | | |
|--------------------------|--|
| S = Single Speed | W = SS/SS = Single Speed Hoist, Single Speed Trolley |
| D = Dual Speed | X = SS/DS = Single Speed Hoist, Dual Speed Trolley |
| PC = Plug Connection | Y = DS/SS = Dual Speed Hoist, Single Speed Trolley |
| 2V = 208/230 Volt Models | Z = DS/DS = Dual Speed Hoist, Dual Speed Trolley |
| | 4V = 460 Volt Models |

2.1 Electric Parts – 1/4 to 2 Ton (Single Speed)

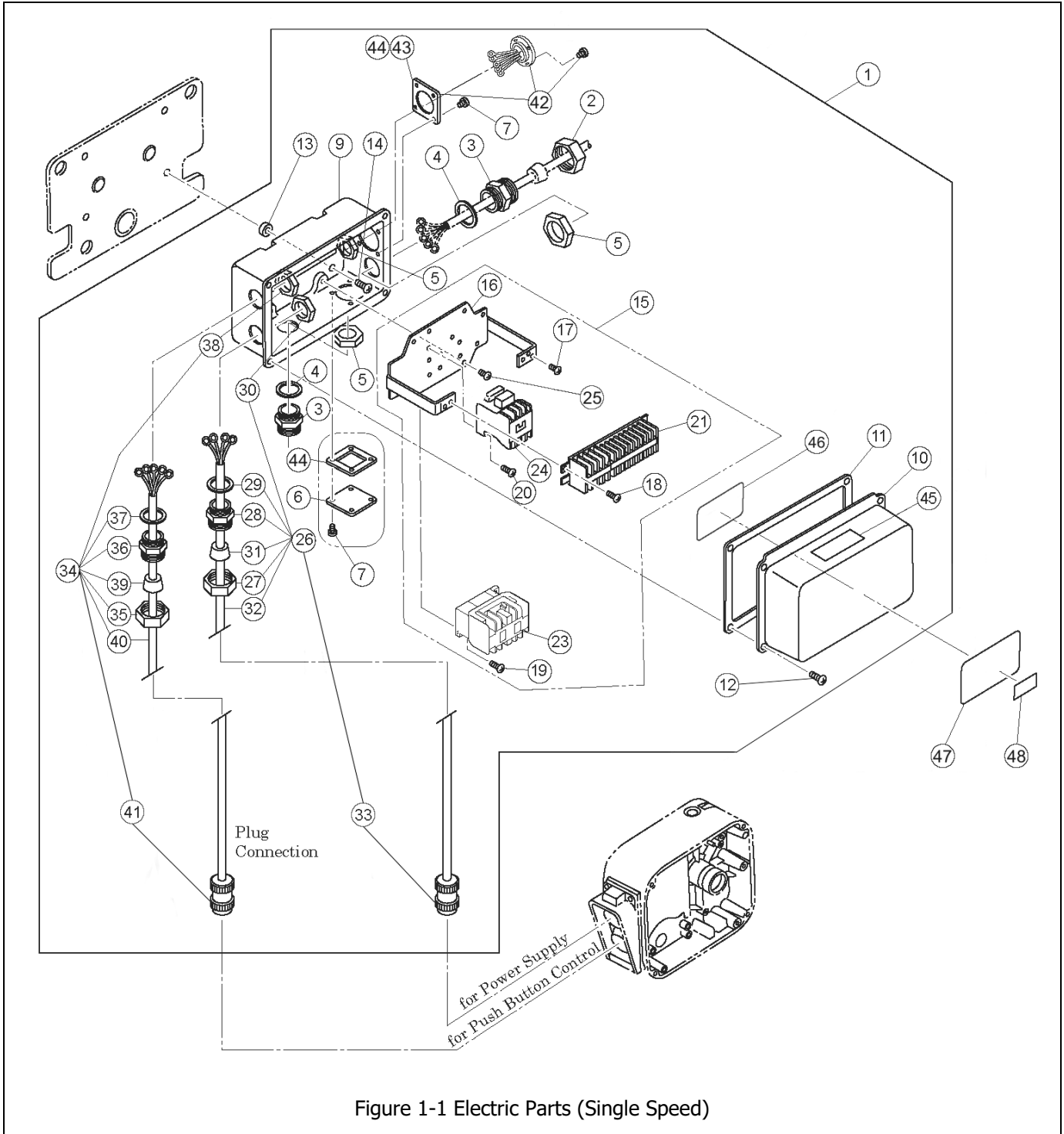

Figure 1-1 Electric Parts (Single Speed)

2.1 Electric Parts– 1/4 to 2 Ton (Single Speed)

Figure No.	Part Name	Parts Per Trolley	1 Ton	2 Ton
1	Connection Box Assembly	1	7038101	7038102
2	Holder A	1	ECP5924AA	
3	Holder B	2	ECP5924AB	
4	Packing	2	ECP5924AC	
5	Holder Nut	2	ECP5924AD	
6	Cord Cover	1	E6F630010S	
7	Machine Screw With Spring Washer	8	J1AP45001010	
9	Connection Box	1	3AFG010S9401	
10	Connection Box Cover	1	3AFG010S9411	
11	Connection Box Packing	1	MR1DS9421	
12	Machine Screw With Spring Washer	4	J1AP45001010	
13	Spacer	4	MS517010	
14	Machine Screw With Spring Washer	4	J1AP48002020	
15	Complete Plate Assembly	1	MR2RHM10M1A5	
16	Plate	1	MR2DS5445	
17	Machine Screw With Spring Washer	3	MS555010	
18	Machine Screw With Spring Washer	2	MS556010	
19	Machine Screw With Spring Washer	2	MS556010	
20	Machine Screw With Spring Washer	2	MS556010	
21	Terminal 16P	1	ECP1416AA	
23	Electromagnetic Contactor	1	MGC22306B	
24	E-Stop Contactor	1	MGC12306B	
25	Machine Screw With Spring Washer	4	MS554010	
26	Power Supply Cable Assembly	1	MR2DS1759	MR2ES1759
27	Holder A	1	ECP5924AA	
28	Holder B	1	ECP5924AB	
29	Packing	1	ECP5924AC	
30	Holder Nut	1	ECP5924AD	
31	Cable Packing	1	ECP6912AA	ECP6916AA
32	S.O. Cord 4C	1	16/4	14/4
33	Plug 4P	1	ECP2304AD	ECP2304AF
34	Control Cable Assembly	1	MR2DS1768	MR2ES1768
35	Holder A	1	ECP5924AA	
36	Holder B	1	ECP5924AB	
37	Packing	1	ECP5924AC	
38	Holder Nut	1	ECP5924AD	
39	Cable Packing	1	ECP6916AA	
40	S.O. Cord 6C	1	16/6P	
41	Plug 8P	1	ECP2108AC	
42	Socket 8P Assembly	1	MR2DS2811	
43	Plate P	1	ECP5924AH	
44	Cord Cover Packing	2	MS527010	
45	Warning Seal E (Electric Shock)	1	ER2CS9936	
46	Wiring Diagram	1	EWG3110H01	
47	Name Plate B	1	MR2SHM10S9A8	
48	Name Plate C	1	MR2SHM10S9A7	MR2SHM20S9A7

Name Plates for 1/8, 1/4, 1/2 & 1 1/2 Ton Capacities

Figure No.	Part Name	Parts Per Trolley	1/8 Ton	1/4 Ton	1/2 Ton	1 1/2 Ton
48	Name Plate C	1	MR2SHM01S9A7	MR2SHM03S9A7	MR2SHM05S9A7	MR2SHM15S9A7

2.1 Electric Parts – 1/4 to 2 Ton (Dual Speed)

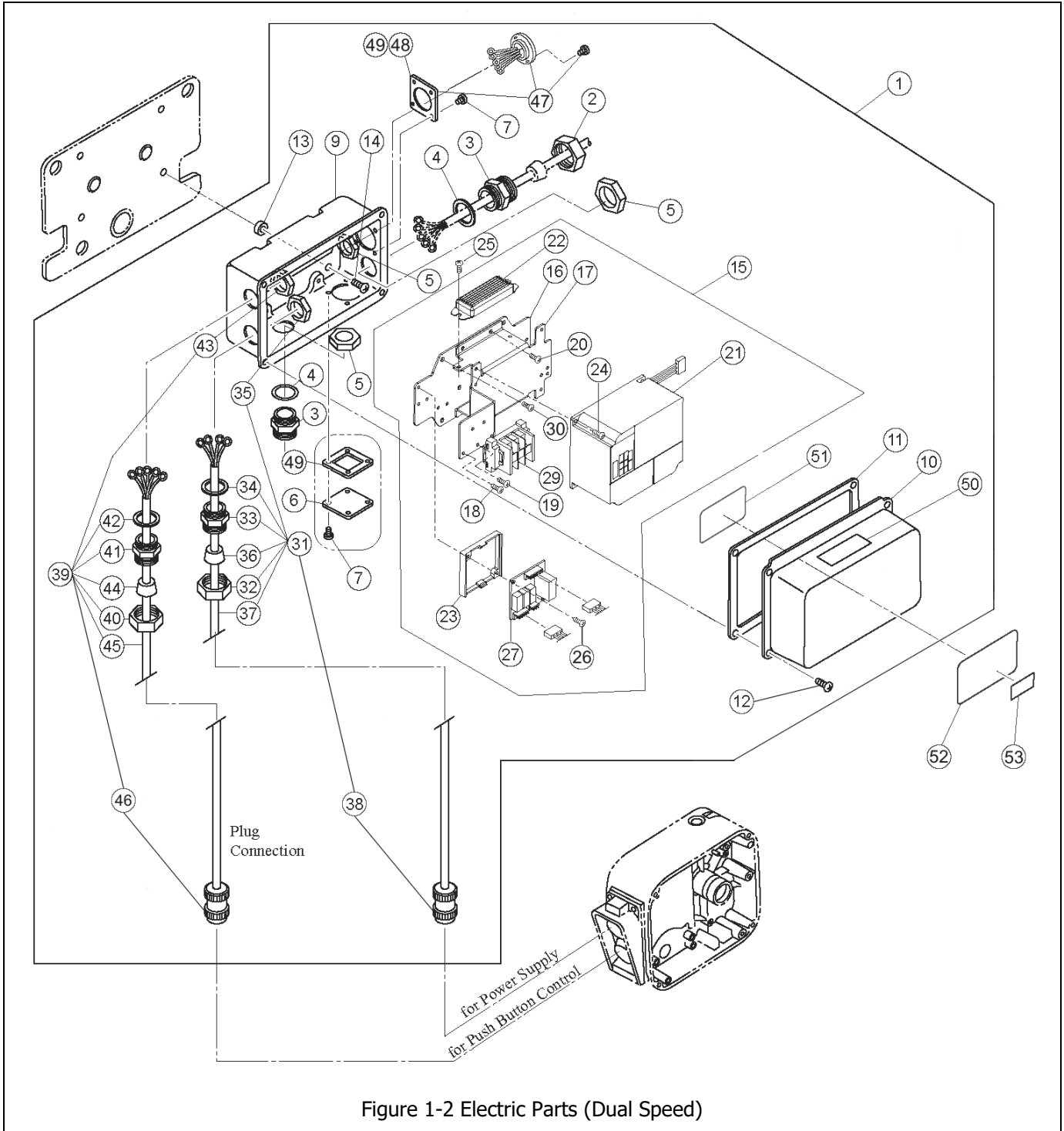

Figure 1-2 Electric Parts (Dual Speed)

2.1 Electric Parts– 1/4 to 2 Ton (Dual Speed)

Figure No.	Part Name	Parts Per Trolley		1 Ton	2 Ton
		2V	4V		
1	Connection Box Assembly	2V	1	7038201	7038202
		4V		7038203	7038204
2	Holder A		1	ECP5924AA	
3	Holder B		2	ECP5924AB	
4	Packing		2	ECP5924AC	
5	Holder Nut		2	ECP5924AD	
6	Cord Cover		1	E6F630010S	
7	Machine Screw With Spring Washer		8	J1AP45001010	
9	Connection Box		1	3AFG010S9401	
10	Connection Box Cover		1	3AFG010S9411	
11	Connection Box Packing		1	MR1DS9421	
12	Machine Screw With Spring Washer		4	J1AP45001010	
13	Spacer		4	MS517010	
14	Machine Screw With Spring Washer		4	J1AP48002020	
15	Complete Plate Assembly	2V	1	MR2IHE10R1A5	MR2IHE20RIA5
		4V		MR2IHN10R1A5	MR2IHN20R1A5
16	Plate		1	MR2DI9441	
17	Plate B		1	MR2DI9443	
18	Machine Screw With Spring Washer		3	MS555010	
19	Machine Screw With Washers		2	J1AW24000808	
20	Machine Screw With Spring Washer		4	MS555010	
21	VFD Assembly	2V	1	INV604E31	
		4V		INV604N31	
22	Braking Resistor	2V	1	INV904E34	
		4V		INV904Y34	
23	Board Support		1	ECP99BKAB	
24	Machine Screw With Spring Washer		2	MS555010	
25	Machine Screw With Washers		2	J1AW24000808	
26	Machine Screw With Spring Washer		2	MS556010	
27	Interface Board		1	ECP91KB12	
29	Terminal 3P		1	ECP1403AA	
30	Machine Screw With Spring Washer		4	MS554010	
31	Power Supply Cable Assembly		1	MR2DS1759	MR2ES1759
32	Holder A		1	ECP5924AA	
33	Holder B		1	ECP5924AB	
34	Packing		1	ECP5924AC	
35	Holder Nut		1	ECP5924AD	
36	Cable Packing		1	ECP6912AA	ECP6916AA
37	S.O. Cord 4C		1	16/4	14/4
38	4P Plug		1	ECP2304AD	ECP2304AF
39	Control Cable Assembly		1	MR2DI1768	MR2EI1768
40	Holder A		1	ECP5924AA	
41	Holder B		1	ECP5924AB	
42	Packing		1	ECP5924AC	
43	Holder Nut		1	ECP5924AD	
44	Cable Packing		1	ECP6916AA	
45	S.O. Cord 6C		1	16/6P	
46	8P Plug		1	ECP2108AC	
47	Socket 8P Assembly	2V	1	MR2DI1811	
		4V		MR2DI2811	
48	Plate P		1	ECP5924AH	
49	Cord Cover Packing		2	MS527010	
50	Warning Seal E (Electric Shock)		1	ER2CS9936	
51	Wiring Diagram		1	EWG3DD0H01	
52	Name Plate B		1	MR2SHM10S9A8	
53	Name Plate C		1	MR2SHM10S9A7	MR2SHM20S9A7

Name Plates for 1/8, 1/4, 1/2 & 1 1/2 Ton Capacities

Figure No.	Part Name	Parts Per Trolley	1/8 Ton	1/4 Ton	1/2 Ton	1 1/2 Ton
53	Name Plate C	1	MR2SHM01S9A7	MR2SHM03S9A7	MR2SHM05S9A7	MR2SHM15S9A7

2.2 Pendant Parts – 1/4 to 2 Ton

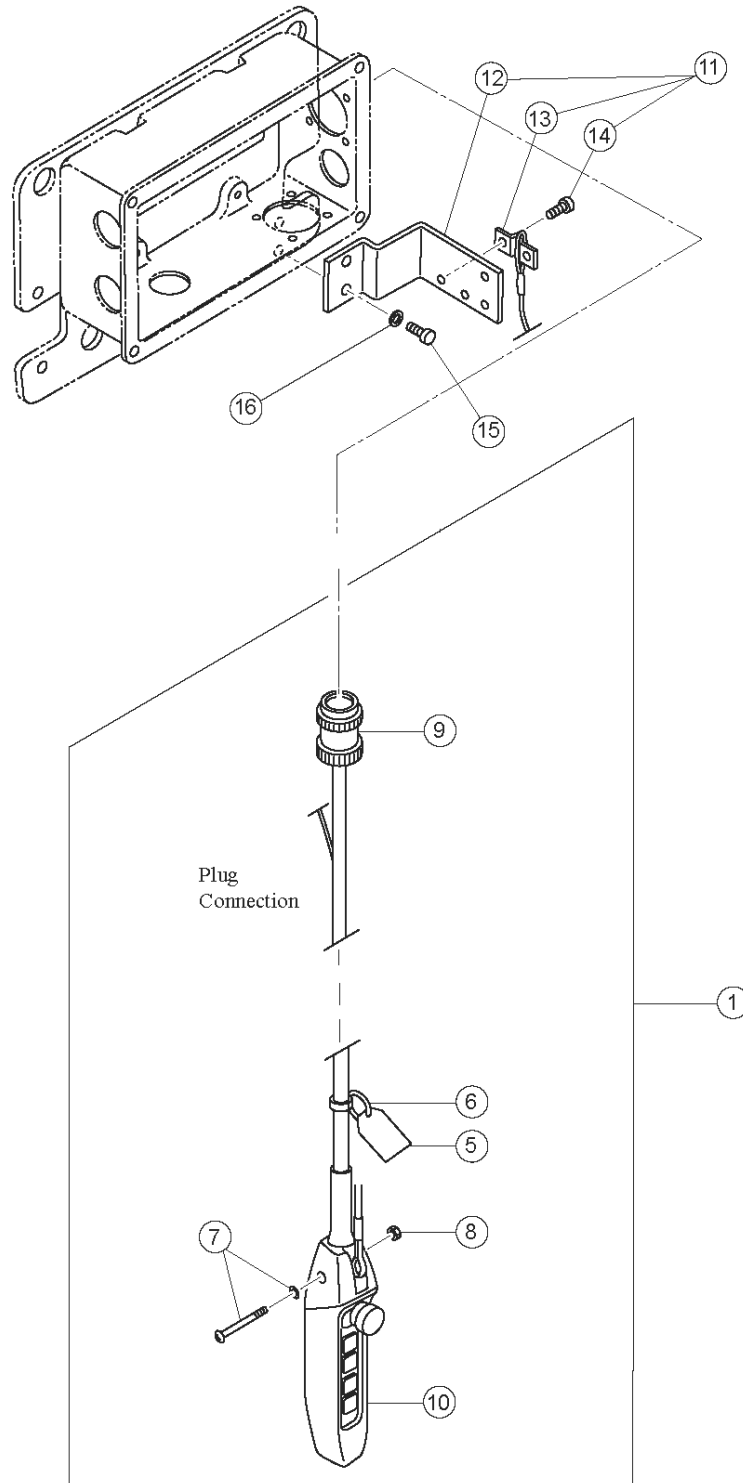
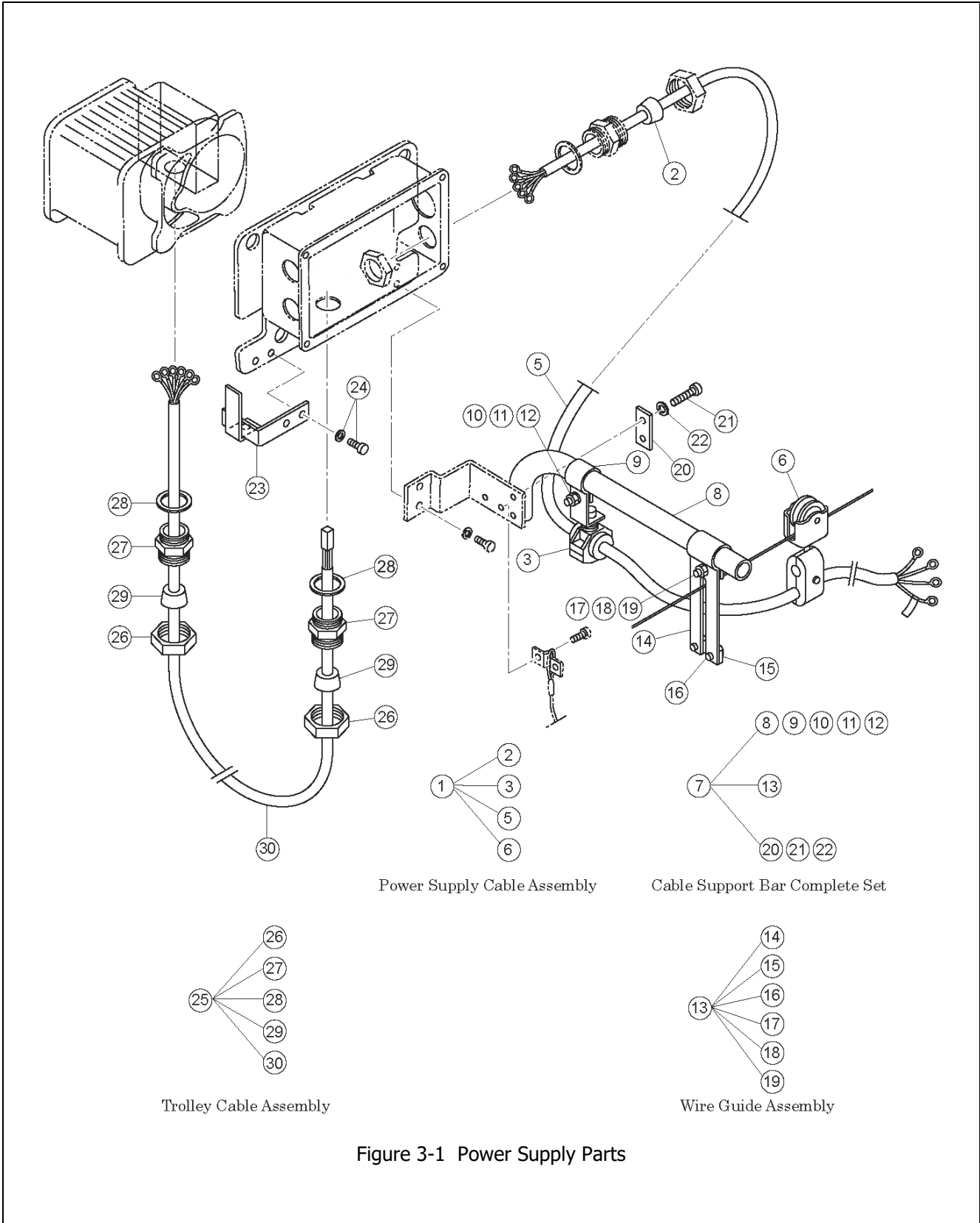

Figure 2-1 Pendant Parts

2.2 Pendant Parts – 1/4 to 2 Ton

Figure No.	Part Name	Parts Per Trolley	1 Ton	2 Ton
1	Push Button Cord 6C/7C/8C Complete Assembly	W	1	ZB1102AI1000
		X		ZB1202AI1000
		Y		ZB2102AI1000
		Z		ZB2202AI1000
4	Push Button Cord 6C	W	1	16/6P
	Push Button Cord 8C	X, Y, Z		16/8P
5	Warning Tag PB	1		WTAG7
6	Tag Holder	1		E3S787003
7	Machine Screw With Spring Washer	1		J1AP24002608
8	Nut	1		9093414
9	Plug 8P	W, PC	1	ECP2108AB
		X, Y, Z, PC		ECP2108AD
10	5 Push Button Switch Assembly	W	1	SWD2110ABH
		X		SWD2120ABH
		Y		SWD2210ABH
		Z		SWD2220ABH
11	Bar Holder Assembly	1		MR1DS1481
12	Bar Holder	1		MR1DS9481
13	Cord Strain Relief Stopper	1		E6L614010S
14	Machine Screw w/Spring Washer	2		E6F151003
15	Socket Bolt	2		J1BEE1002828
16	Spring Washer	2		J1WS07420100

2.3 Power Supply Parts – 1/4 to 2 Ton



2.3 Power Supply Parts – 1/4 to 2 Ton

Figure No.	Part Name	Parts Per Trolley	1 Ton	2 Ton
1	Power Supply Cable 4C Assembly	1	ZBZC12AH1100	ZBZC12BH1100
2	Cable Packing	1	ECP6914AA	ECP6916AA
3	Cable Support 14 Assembly	1	M3ES0101724	
5	Power Supply Cable 4C	1	14/4	12/4
6	Cable Hanger 14 Assembly	A/R	ES1527003	MS1733020
7	Cable Support Bar Assembly	1	MR1DS1491	
8	Cable Support Bar	1	MR1DS9491	
9	Cable Support Arm	1	MR1DS9492	
10	Bolt	1	9093328	
11	Spring Lock Washer	1	9012711	
12	Nut	1	9093424	
13	Wire Guide Assembly	1	MR1DS1493	
14	Wire Guide	1	MR1DS9493	
15	Wire Stopper	1	MR1DS9496	
16	Machine Screw With Spring Washer	2	M6F554010	
17	Bolt	1	9093328	
18	Spring Lock Washer	1	9012711	
19	Nut	1	9093424	
20	Support Bar Holder (Plate)	1	MR1DS9501	
21	Bolt	2	9093329	
22	Spring Lock Washer	2	9012711	
23	Cable Hanger Pusher (Beam 75mm)	1	3AFG010S9511	
	Cable Hanger Pusher (Beam 100-150mm)	1	3AFG010S9512	
24	Socket Bolt With Spring Washer	2	J1BGE1002828	
25	Trolley Cable 6C Assembly	1	MR2DS1793	
26	Holder A	2	ECP5924AA	
27	Holder B	2	ECP5924AB	
28	Packing	2	ECP5924AC	
29	Cable Packing	2	ECP6912AA	
30	Trolley Cable 6C	1	16/6	

*A/R = As Required, one for every 5 ft of power Supply Cable.

2.4 Side Plates and Suspension Parts – 1/4 to 2 Ton

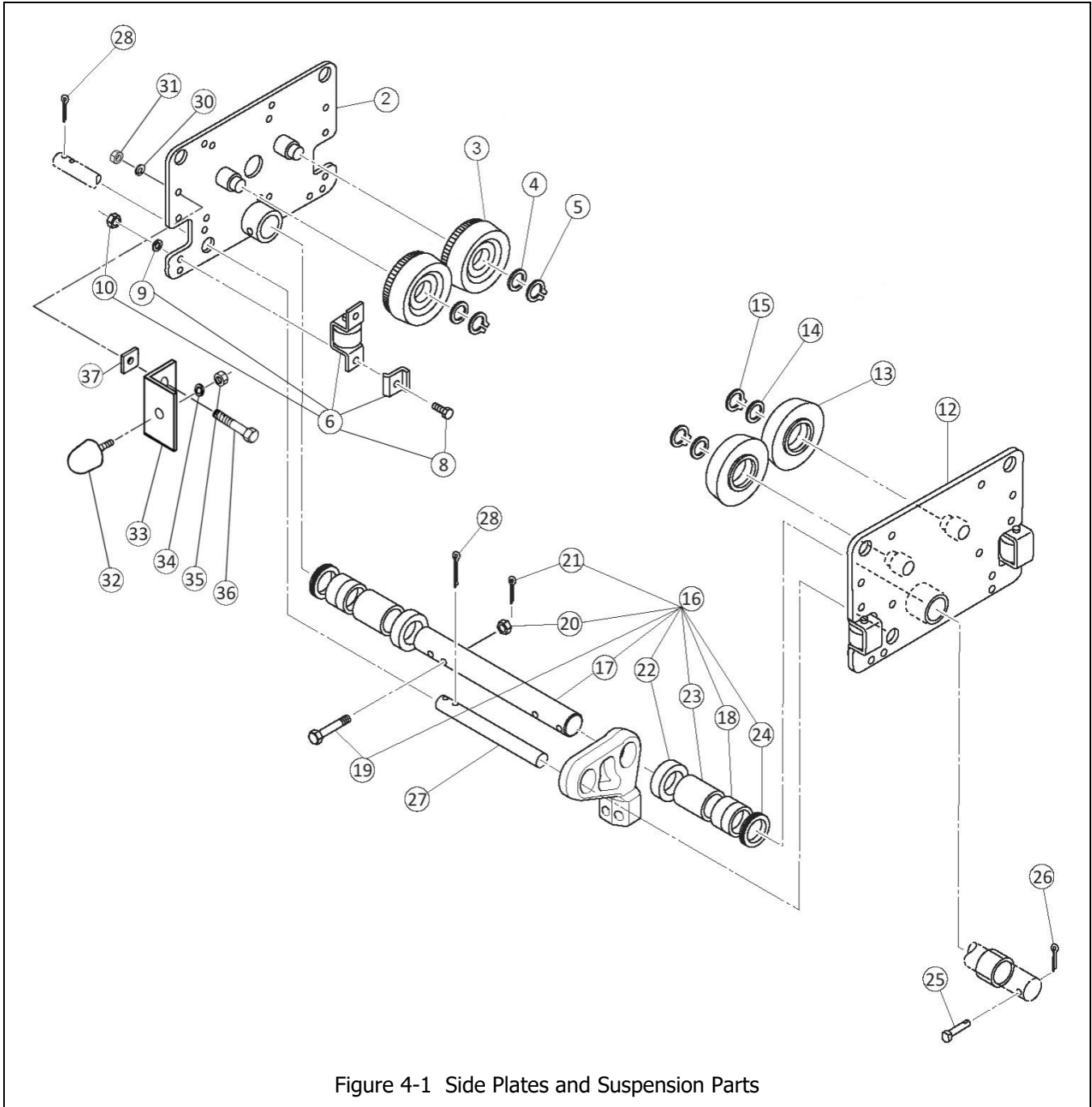

Figure 4-1 Side Plates and Suspension Parts

2.4 Side Plates and Suspension Parts– 1/4 to 2 Ton

Figure No.	Part Name	Parts Per Trolley	1 Ton	2 Ton
2	Side Plate G Assembly	1	3AFG010S5201	3AFG020S5201
3	Track Wheel G Assembly – Standard	2	MS1101010	MS1101020
	Track Wheel G Assembly – Stainless Steel		35MW0105101	35MW0205101
4	Washer	2	MS104010	MS104020
5	Snap Ring – Standard	2	9047115	9047120
	Snap Ring – Stainless Steel		J1SS10000015	J1SS10000020
6	Side Roller Assembly – Standard	4	3AFG010S1211	3AFG020S1211
	Side Roller Assembly – Stainless Steel		3AFG010S2211	3AFG020S2211
8	Bolt	4	J1BAE0803535	J1BAE1004040
9	Spring Lock Washer	4	J1WS07420080	J1WS07420100
10	Nut	4	J1NA00920080	J1NA00920100
12	Side Plate S Assembly	1	3AFG010S5202	3AFG020S5202
13	Track Wheel S Assembly – Standard	2	MS1102010	MS1102020
	Track Wheel S Assembly – Stainless Steel		35MW0105102	35MW0205102
14	Washer	2	J1WB07410080	J1WB07410100
15	Snap Ring – Standard	2	9047115	9047120
	Snap Ring – Stainless Steel		J1SS10000015	J1SS10000020
16	Suspension Shaft Assembly – Standard Shaft	1	3AFG010S2101	3AFG020S2101
	Suspension Shaft Assembly – Nickel Plated Shaft		3AFG010S3101	3AFG020S3101
17	Suspension Shaft – Standard	1	MSF115010	MSF115020
	Suspension Shaft – Nickel Plated		3AFG010S9115	3AFG020S9115
18	Thick Spacer	3	MSF116010	T7G116030
19	Bolt	1	3AFG010S9103	3AFG020S9103
20	Slotted Nut	1	J1NL00910100	
21	Split Pin	1	J1PW06025018	
22	Thick Spacer L	2	MR1DS9110	MR1ES9110
24	Thin Spacer	8	MSF117010	MSF117020
25	Shaft Stopper	1	T6G156020	MS164020
26	Split Pin	1	J1PW06040020	
27	Fixing Shaft – Standard	1	MR1DS9131	MR1ES9131
	Fixing Shaft – Nickel Plated		3AFG010S9131	3AFG020S9131
28	Split Pin	2	J1PW06050040	
30	Spring Washer	8	J1WS07420080	
31	Nut	8	J1NA00920080	J1NA00920100
32	Bumper	4	MR1DS9631	
33	Bumper Lug	4	3AFG010S9361	3AFG020S9361
34	Spring Washer	4	J1WS07420080	
35	Nut	4	J1NA00920080	
36	Bolt	8	J1BEB0803535	J1BEB1004526
37	Square Spacer	4	MS006010	MS006020

Extended Suspension Shaft Assemblies

Figure No.	Part Name	Parts Per Trolley	1 Ton	2 Ton
16	Extended Suspension Shaft Assembly – Standard Shaft	1	37FG010S1121	37FG020S1121
	Extended Suspension Shaft Assembly – Nickel Plated Shaft	1	37FG010S3121	37FG020S3121
17	Extended Suspension Shaft – Standard	1	MSF181010	MSF181020
	Extended Suspension Shaft – Nickel Plated		3AFG010S9181	3AFG020S9181
18	Thick Spacer	9	MSF116010	T7G116030
19	Bolt	1	3AFG010S9103	3AFG020S9103
20	Slotted Nut	1	J1NL00910100	
21	Split Pin	1	J1PW06025018	
22	Thick Spacer L	2	MR1DS9110	MR1ES9110
23	Fixing Spacer	2	M7SE010S9182	M7SE020S9182
24	Thin Spacer	8	MSF117010	MSF117020
27	Fixing Shaft – Standard	1	MR1DS9141	MR1ES9141
	Fixing Shaft – Nickel Plated		3AFG010S9141	3AFG020S9141
28	Split Pin	2	J1PW06050040	

This Page Intentionally Left Blank

2.5 Motor Parts – 1/4 to 2 Ton

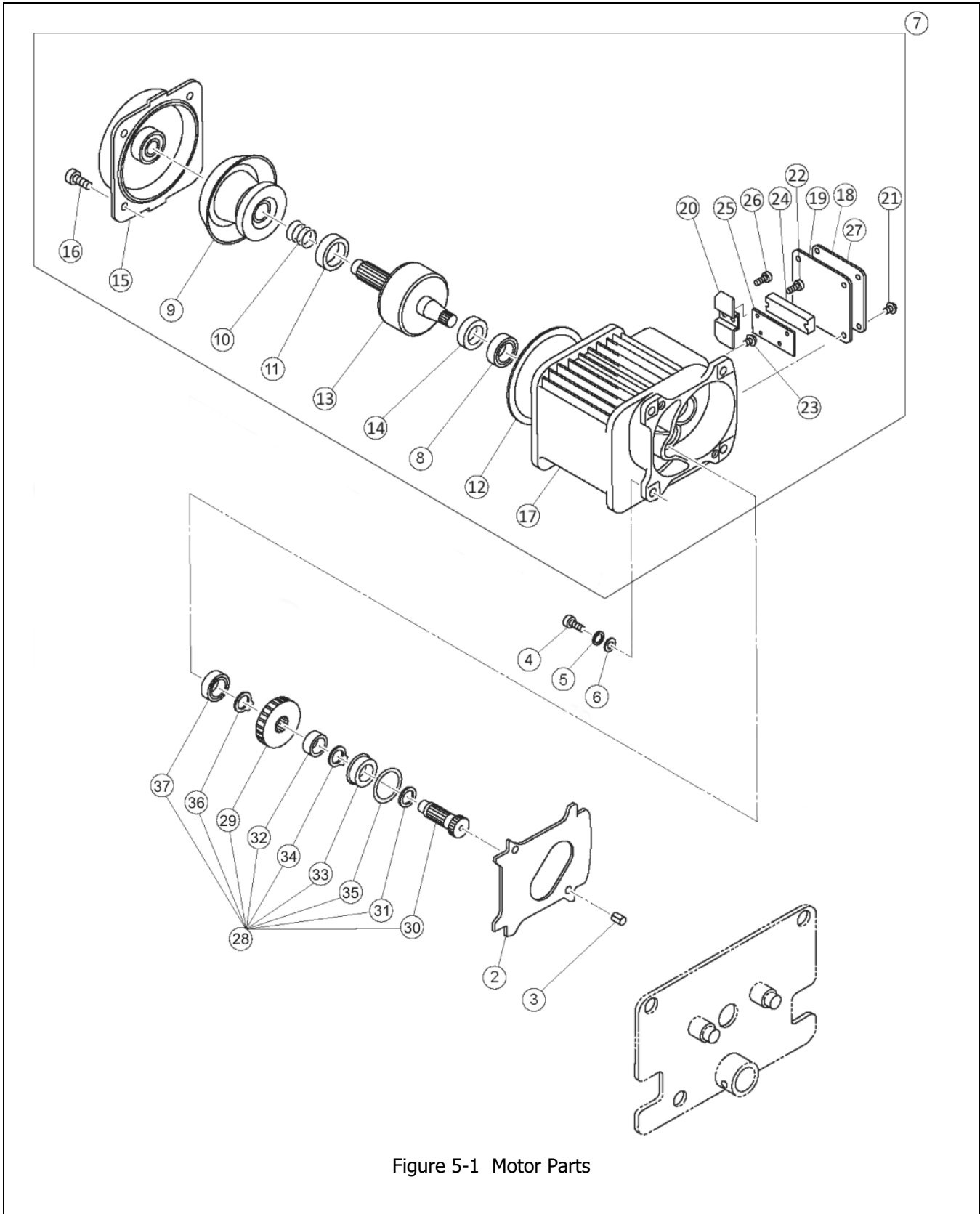

Figure 5-1 Motor Parts

2.5 Motor Parts – 1/4 to 2 Ton

Figure No.	Part Name	Parts Per Trolley	1 Ton	2 Ton
2	Gear Box Packing	1	MR1DS9248	
3	Set Pin	2	MR1DS9249	
4	Bolt	4	J1BAE0802525	
5	Spring Lock Washer	4	J1WS07420080	
6	Washer	4	J1WB07400080	
7	Motor Assembly	1	3AFG010S1321	
8	Ball Bearing	1	9001004	
9	Brake Drum Assembly	1	MR1DS5261	
10	Brake Spring	1	MS304010	
11	Bumper	1	MR1DS9265	
12	Guard	1	MR1DS9281	
13	Motor Shaft With Rotor	1	MR1DS5291	
14	Oil Seal	1	MR1DS9293	
15	Motor Cover Assembly	1	3AFG010S1301	
16	Socket Bolt	4	J1BEE0802222	
17	Motor Frame With Stator	1	3AFG010S5321	
18	Terminal Cover	1	3AFG010S9324	
19	Terminal Cover Packing	1	MR1DS9325	
20	Coil Cover	1	MR1DS9326	
21	Machine Screw With Spring Washer	4	J1AP45001010	
22	Machine Screw With Spring Washer	2	MS556010	
23	Machine Screw With Spring Washer	1	MS555010	
24	Terminal 6P	1	ECP1306AB	
25	Terminal Plate Holder	1	MR1DS9855	
26	Flat Head Tapping Screw	2	9096529	
27	Motor Data Plate	1	IMNBH04VT	
38	Washer	1	J1WD07420050	

Figure No.	Part Name	Parts Per Trolley	1 Ton S/SD	1 Ton L/LD	2 Ton S/SD	2 Ton L/LD
28	Gear Assembly	1	MR1DS1241	MR1DL1241	MR1ES1241	MR1EL1241
29	Gear #2	1	MR1DS9241	MR1DL9241	MR1DS9241	MR1DL9241
30	Gear #3	1	MR1DS9242		MR1ES9242	
31	O Ring	1	9013316			
32	Spacer	1	MR1DS9244			
33	Ball Bearing	1	9001211			
34	Snap Ring	2	9047120			
35	O Ring	1	MR1DS9254			
36	Snap Ring	1	9047120			
37	Ball Bearing	1	E2D238125			

This Page Intentionally Left Blank

3.0 TS2 Parts List

When ordering parts, please provide the hoist code number, lot number and serial number located on the hoist nameplate (see fig. below).

Reminder: To aid in ordering parts and product support, record the hoist code number, lot number and serial number in the space provided on the cover of this manual.

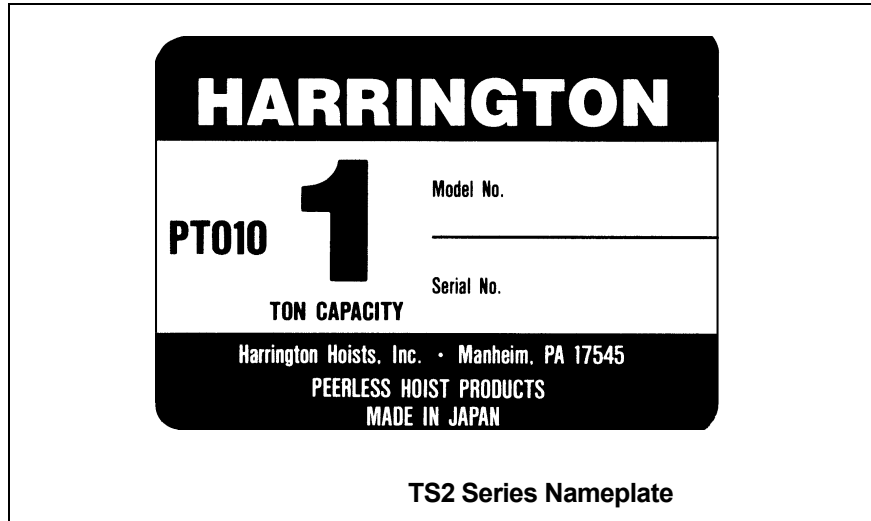

The parts list is arranged into the following sections:

Section	Page
3.1 TS2 Push Trolley Parts – 1/4 to 2 Ton.....	60
3.2 TS2 Geared Trolley Parts – 1/4 to 2 Ton.....	62

3.1 TS2 Push Trolley Parts – 1/4 to 2 Ton

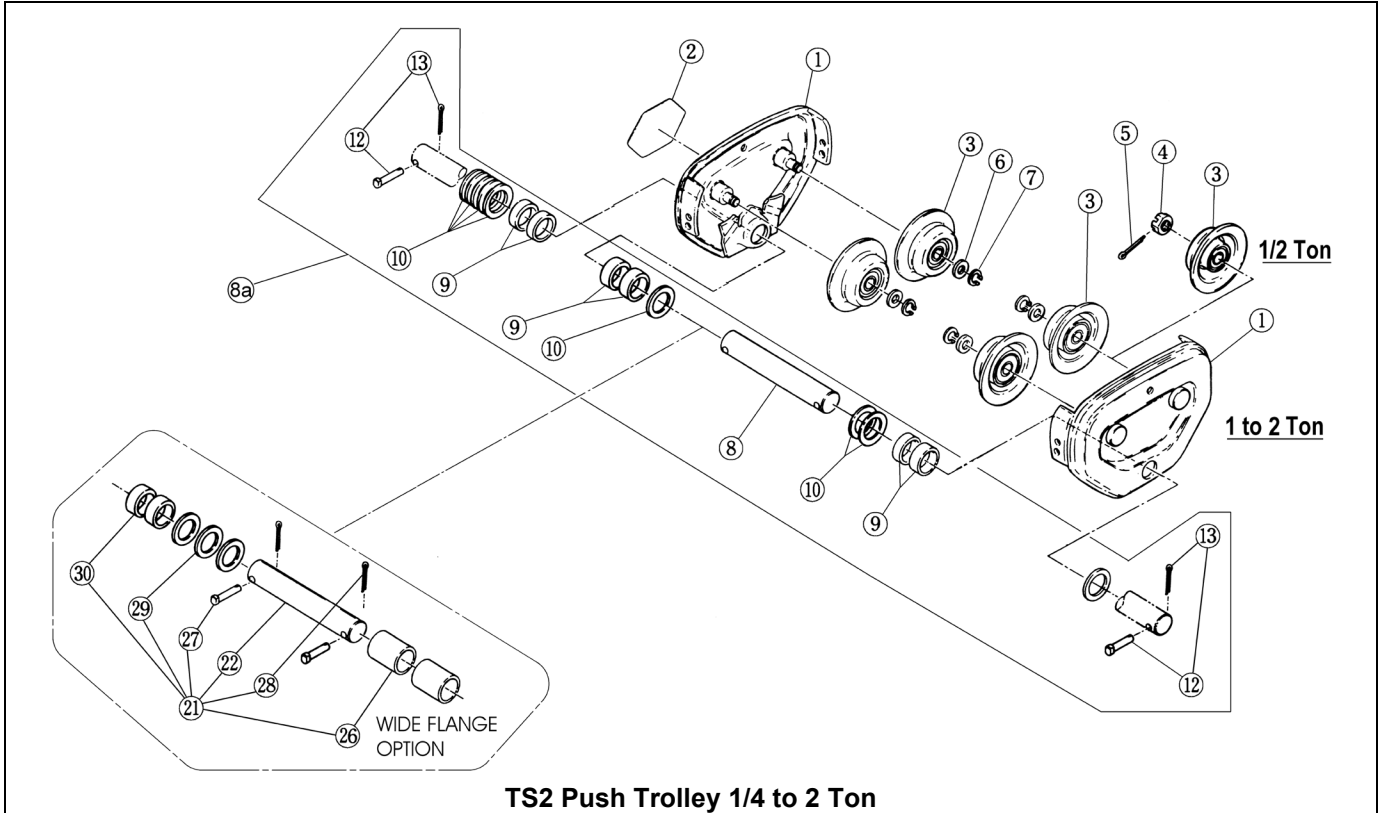

3.2 TS2 Geared Trolley Parts – 1/4 to 2 Ton

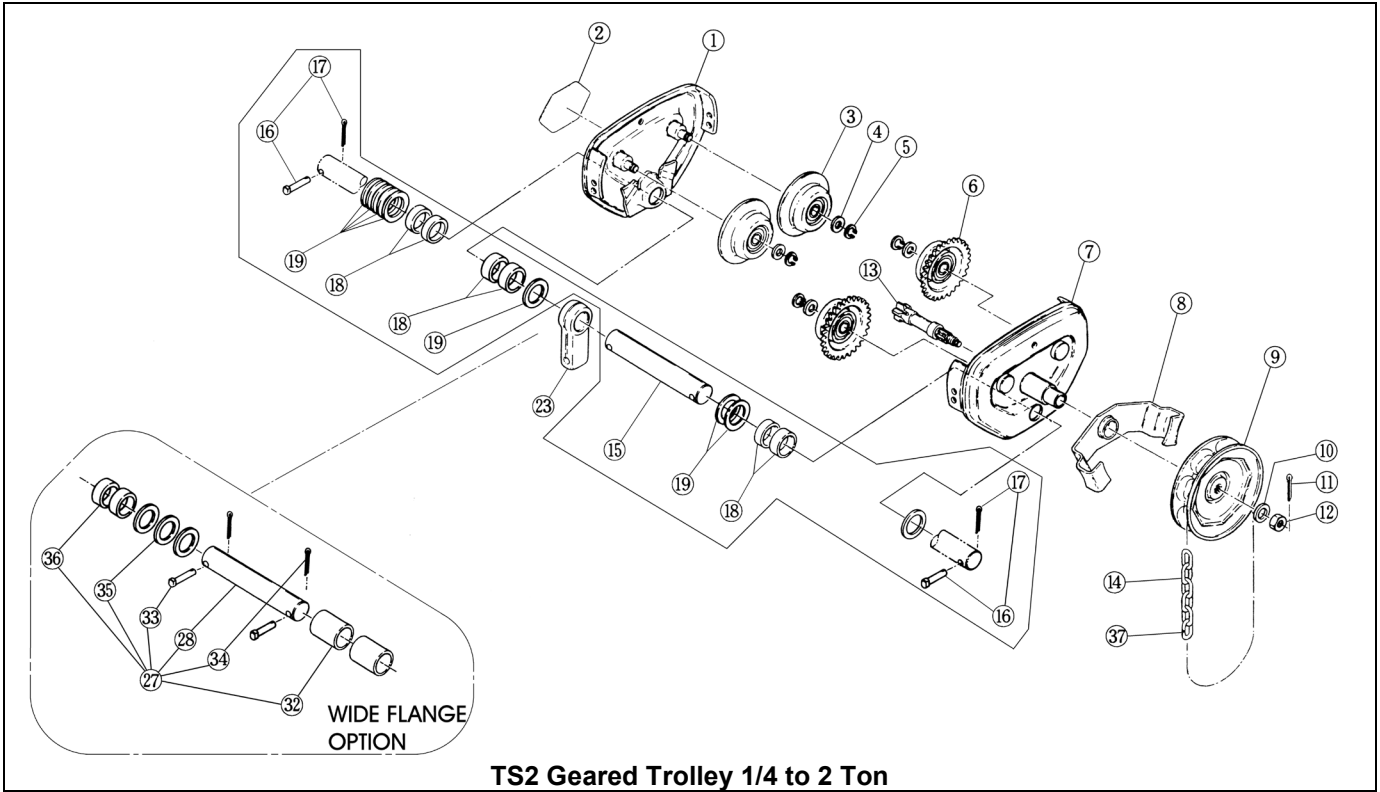



Harrington Hoists, Inc.
401 West End Avenue
Manheim, PA 17545

www.harringtonhoists.com

Toll Free: 800-233-3010
Phone: 717-665-2000
Fax: 717-665-2861

© HARRINGTON HOISTS, INC.
ALL RIGHTS RESERVED

ER2FGSUP-ENG