

---

# OWNER'S MANUAL

---

## FREE STANDING JIB CRANE 350 Series

1/8 Ton through 1 Ton Capacity

Product Code and Serial Number

### **⚠ WARNING**

This equipment should not be installed, operated or maintained by any person who has not read and understood all the contents of this manual. Failure to read and comply with the contents of this manual can result in serious bodily injury or death, and/or property damage.



# Table of Contents

<b>Section</b>	<b>Page Number</b>
1.0 Important Information and Warnings.....	3
1.1 Terms and Summary	
1.2 Warning Tags and Labels	
2.0 Technical Information.....	6
2.1 Specifications & Dimensions	
2.3 Crane Terms	
3.0 Pre-operational Procedures.....	9
3.1 Pre-Assembly	
3.2 Installation	
3.3 Mechanical Rotation Stops	
3.4 Tight Wire Assembly	
4.0 Operation.....	15
4.1 Introduction	
4.2 Shall's and Shall Not's for Operation	
4.3 Jib Boom Operation	
4.4 Trolley Operation	
4.5 Hoist Operation	
5.0 Inspection.....	18
6.0 Lubrication.....	19
7.0 Troubleshooting.....	20
8.0 Warranty.....	21
9.0 Parts Information.....	23

## 1.0 Important Information and Warnings

### 1.1 Terms and Summary

**This manual provides important information** for personnel involved with the installation, operation and maintenance of this product. Although you may be familiar with this or similar equipment, it is strongly recommended that you read this manual before installing, operating or maintaining the product.

**Danger, Warning, Caution and Notice** - Throughout this manual there are steps and procedures that can present hazardous situations. The following signal words are used to identify the degree or level of hazard seriousness.

**▲ DANGER** Danger indicates an imminently hazardous situation which, if not avoided, **will** result in **death or serious injury**, and property damage.

**▲ WARNING** Warning indicates an imminently hazardous situation which, if not avoided, **could** result in **death or serious injury**, and property damage.

**▲ CAUTION** Caution indicates a potentially hazardous situation which, if not avoided, **may** result **minor or moderate injury** or property damage.

**NOTICE** Notice is used to notify people of installation, operation, or maintenance information which is important but not directly hazard-related.

### ▲ CAUTION

These general instructions deal with the normal installation, operation, and maintenance situations encountered with the equipment described herein. The instructions should not be interpreted to anticipate every possible contingency or to anticipate the final system, crane, or configuration that uses this equipment. For systems using the equipment covered by this manual, the supplier and owner of the system are responsible for the system's compliance with all applicable industry standards, and with all applicable federal, state and local regulations/codes.

This manual includes instructions and parts information for a variety of crane types. Therefore, all instructions and parts information may not apply to any one type or size of a specific crane. Disregard those portions of the instructions that do not apply.

Record your crane's Model and Serial Number (see **Section 9**) on the front cover of this manual for identification and future reference to avoid referring to the wrong manual for information or instructions on installation, operation, inspection, maintenance, or parts.

Use only Harrington authorized replacement parts in the service and maintenance of this crane.

## **WARNING**

Equipment described herein is not designed for and **MUST NOT** be used for lifting, supporting, or transporting people, or for lifting or supporting loads over people.

Equipment described herein should not be used in conjunction with other equipment unless necessary and/or required safety devices applicable to the system, crane, or application are installed by the system designer, system manufacturer, crane manufacturer, installer, or user.

Modifications to upgrade, rerate, or otherwise alter this equipment shall be authorized only by the original equipment manufacturer.

Cranes, used to handle hot molten material may require additional equipment or devices. Refer to ASTM E2349 "Standard Practice for Safety Requirements in Metal Casting Operations: Sand Preparation, Molding, and Core Making; Melting and Pouring; and Cleaning and Finishing".

Only trained and competent personnel should inspect and repair this equipment. Only competent erection personnel familiar with standard fabrication practices should be employed to assemble Harrington's cranes because of necessity in interpreting these instructions. Harrington is not responsible for quality of workmanship performed during crane installation.

Consult with a qualified structural engineer to determine if your support structure is adequate to support the loads generated by anchor bolt force, overturning moment, or axial load of your crane.

Crane cannot be utilized as a ground: a separate ground wire is required.

Overloading and improper use can result in injury.

All welds must meet American Welding Society (AWS) specification D14.1 "Specification for Welding of Industrial and Mill Cranes and other Material Equipment."

Failure to read and comply with any one of the limitations noted herein can result in serious bodily injury or death, and/or property damage.

## NOTICE

It is the responsibility of the owner/user to install, inspect, test, maintain, and operate a crane in accordance with the applicable portions of OSHA Specification 1910.179 "Overhead and Gantry Cranes," ANSI B30.11, "Monorails and Underhung Cranes," and any other applicable standards.

It is the responsibility of the owner/user to have all personnel that will install, inspect, test, maintain, and operate a crane read the contents of this manual and applicable portions of OSHA Specification 1910.179 "Overhead and Gantry Cranes," ANSI B30.11, "Monorails and Underhung Cranes," and any other applicable standards.

If the crane owner/user requires additional information, or if any information in the manual is not clear, contact Harrington or the distributor of the crane. Do not install, inspect, test, maintain, or operate this crane unless this information is fully understood.

A regular schedule of inspection of the crane in accordance with the requirements of OSHA Specification 1910.179 "Overhead and Gantry Cranes," ANSI B30.11, "Monorails and Underhung Cranes," and any other applicable standards should be established and records maintained.

Dimensions and figures contained in this manual are for reference only and may differ for your particular application. Please refer to the Foundation Drawing and Jib Crane Drawing included with crane.

### 1.2 Warning Tags and Labels

This crane may be part of a lifting system including a hoist and trolley. It is the responsibility of the owner of such a lifting system to ensure that the lifting system be equipped with warning labels in accordance with applicable industry standards.

## 2.0 Technical Information

### 2.1 Specifications & Dimensions

#### 2.1.1 Product Code

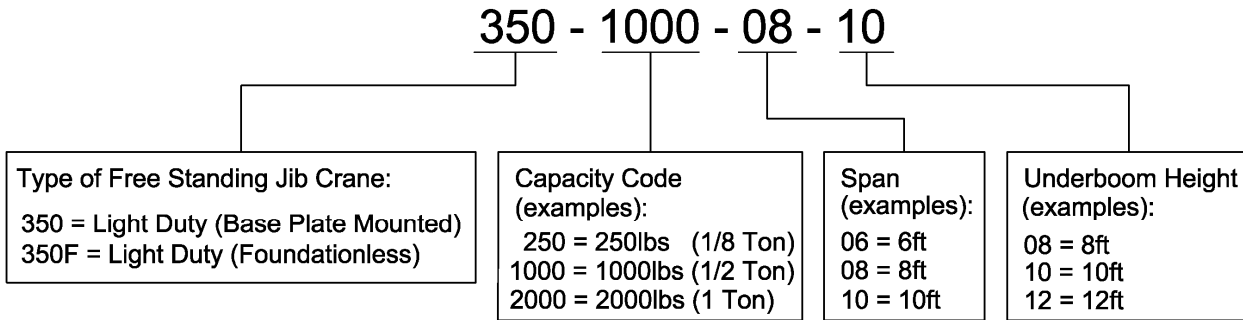

#### 2.1.2 Operating Conditions and Environment

Temperature range: -30°F to +150°F (-34°C to 66°C)

Relative Humidity: 85% or less

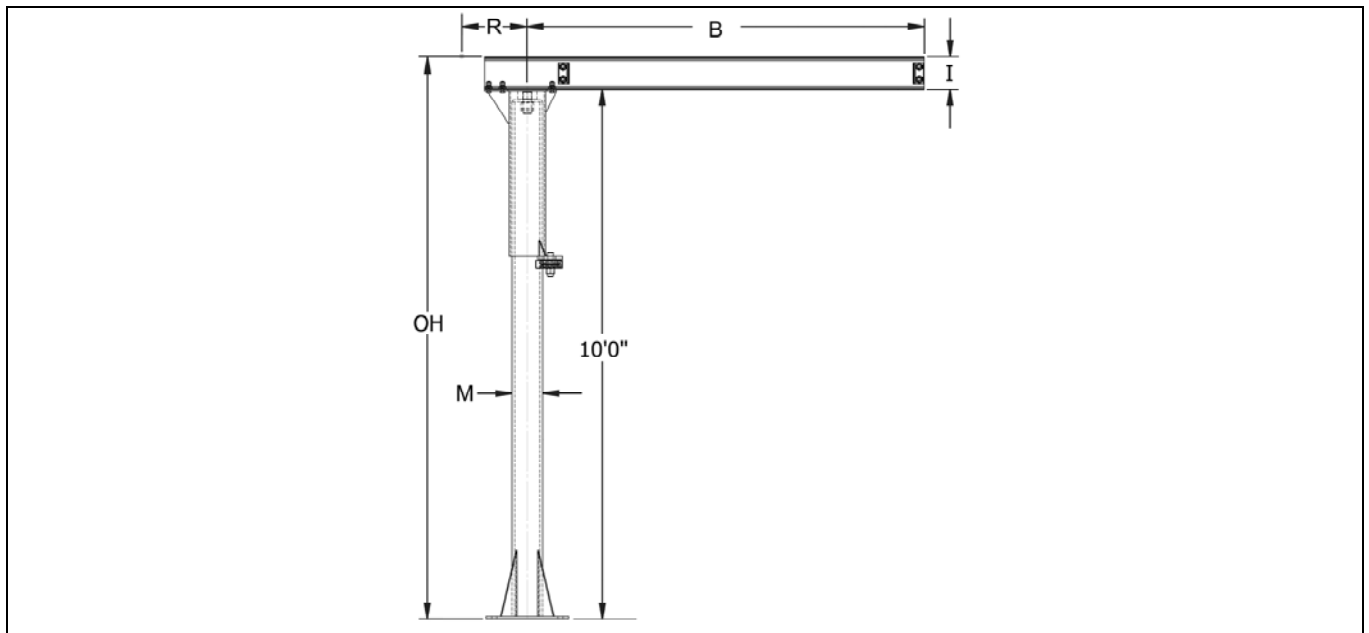

**Table 2-1 Model 350\* Specifications & Dimensions\*\* (Light Duty – Base Mounted)**  
Under Boom Height of 10ft.

Capacity (Ton)	Product Code	Span B (Feet-Inches)	Overall Height OH (Feet-Inches)	Beam Size I (Inches)	Mast Dia M (Inches)	Rotation Clearance R (Inches)	Base Plate Model No.	Weight (Lbs.)	Foundation Size (Feet)
1/8	350-250-06-10	6'-0"	10'-6"	6"	5-9/16"	10	5B	360	4' x 4' x 3'
	350-250-08-10	8'-0"	10'-6"	6"	5-9/16"	10	5B	380	4' x 4' x 3'
	350-250-10-10	10'-0"	10'-6"	6"	5-9/16"	10	5B	495	4' x 4' x 3'
	350-250-12-10	12'-0"	10'-6"	6"	5-9/16"	10	5B	515	4' x 4' x 3'
	350-250-14-10	14'-0"	10'-8"	8"	8-5/8"	12-1/2	8A	813	4' x 4' x 4'
1/4	350-500-06-10	6'-0"	10'-6"	6"	5-9/16"	10	5B	427	4' x 4' x 3'
	350-500-08-10	8'-0"	10'-6"	6"	5-9/16"	10	5B	454	4' x 4' x 3'
	350-500-10-10	10'-0"	10'-8"	8"	8-5/8"	12-1/2	8A	733	4' x 4' x 4'
	350-500-12-10	12'-0"	10'-8"	8"	8-5/8"	12-1/2	8A	774	4' x 4' x 4'
	350-500-14-10	14'-0"	10'-8"	8"	8-5/8"	12-1/2	8A	817	4' x 4' x 4'
1/2	350-1000-06-10	6'-0"	10'-8"	8"	8-5/8"	12-1/2	8A	642	4' x 4' x 4'
	350-1000-08-10	8'-0"	10'-8"	8"	8-5/8"	12-1/2	8A	680	4' x 4' x 4'
	350-1000-10-10	10'-0"	10'-8"	8"	8-5/8"	12-1/2	8A	737	4' x 4' x 4'
	350-1000-12-10	12'-0"	10'-8"	8"	10-3/4"	14-1/2	8C	1160	5.5' x 5.5' x 3.5'
	350-1000-14-10	14'-0"	10'-10"	10"	10-3/4"	14-1/2	8C	1194	5.5' x 5.5' x 3.5'
3/4	350-1500-06-10	6'-0"	10'-8"	8"	8-5/8"	12-1/2	8A	642	4' x 4' x 4'
	350-1500-08-10	8'-0"	10'-8"	8"	10-3/4"	14-1/2	8C	680	5.5' x 5.5' x 3.5'
	350-1500-10-10	10'-0"	10'-8"	8"	10-3/4"	14-1/2	8C	998	5.5' x 5.5' x 3.5'
	350-1500-12-10	12'-0"	10'-10"	10"	10-3/4"	14-1/2	8C	1138	5.5' x 5.5' x 3.5'
1	350-2000-06-10	6'-0"	10'-8"	8"	10-3/4"	14-1/2	8C	739	5.5' x 5.5' x 3.5'
	350-2000-08-10	8'-0"	10'-8"	8"	10-3/4"	14-1/2	8C	795	5.5' x 5.5' x 3.5'
	350-2000-10-10	10'-0"	10'-10"	10"	10-3/4"	14-1/2	8C	1082	5.5' x 5.5' x 3.5'

\*Other spans, capacities, under boom height, etc. are available. Contact Customer Service.

\*\*For Model 350F, please refer to Crane Drawing included with crane for all specifications and dimensions

## 2.3 Crane Terms

In order to better understand jib cranes, here are the commonly used terms that are used to specify and design jibs:

- **Anchor Bolts:** Large steel bolts used to mount a base mounted pillar jib crane to the Harrington recommended foundation.
- **Boom:** The horizontal beam on which the hoist trolley travels.
- **Fitting Centers:** The distance, centerline to centerline, between two support brackets (fittings) of a wall mounted jib crane.
- **Capacity:** The maximum live weight that the crane is designed to support.
- **End Stops:** Bolted to each end of the boom to prevent the trolley from falling off of the beam.
- **Foundation:** For free standing pillar base mounted jibs. Foundations are used to support the jib and prevent it from tipping over.
- **Gussets:** Reinforcing plates used to stiffen mast at the base plate.
- **Head:** Houses the roller, and lowers the crushing forces that are imposed on the mast.
- **Height Under the Boom (H.U.B.):** The distance from the finished floor to the underside of the crane boom. To find the underboom, take the height of the load, plus the distance the load is lifted, plus the headroom requirements of the hoist/trolley and any attachments. Extra room in addition to the minimum required H.U.B. may be helpful for crane operations.
- **Mast:** The vertical member of the jib, which supports the crane. Pillar jibs have round pipes as masts.
- **Overall Height:** The highest point of the jib crane (including any hardware). A minimum clearance (usually 3") is required from any overhead obstruction.
- **Hoist:** The actual lifting mechanism (powered by electric, air, or manual movement) that hangs from the trolley that rides on the boom of a jib crane.
- **Trolley:** The mechanism that travels back and forth on the crane boom (powered by electric, air, or manual movement) which the hoist hangs from.
- **Overturning Moment:** The force applied to the mounting structure of a self-supporting pillar jib. This force is caused by suspending a load from the boom, and is at maximum with full load at the end of the boom.
- **Rotation Stops:** Limits the rotation of a pillar base mounted jib crane boom (which are standard at 360°). Stops are field welded to the mast.
- **Span:** The span for a pillar base mounted jib crane is the distance from the center of the mast to the end of the boom. The span for a column mounted crane is measured from the face of the mounting surface to the end of the boom. The span for a mast type jib crane is measured from the center of the vertical mast to the end of the boom.
- **Thrust and Pull:** Thrust and Pull are forces applied to a wall/column mounted jib cranes support structure. Thrust is the pushing force exerted on the structure, and pull is the tensile, or pulling force. Thrust and Pull are equal to each other (but opposite in direction), and are given at maximum with full load at the end of the boom.
- **Clear Span:** The measurement between the end stops on a crane boom.
- **Hook Travel:** The distance that the hook on the hoist travels.



## 3.0 Preoperational Procedures

### 3.1 Pre-Assembly

- 3.1.1 Check jib crane for physical damage due to shipping.
- 3.1.2 Ensure all capacity stickers and warning labels are clearly visible and properly affixed.
- 3.1.3 Check packing list to ensure no parts have been lost prior to initiating assembly of crane.
- 3.1.4 See Foundation Drawing and Jib Crane Drawing for bolt locations and dimensions.
- 3.1.5 Read entire manual before installing the crane.
- 3.1.6 Identify crane model (Model 350 has a poured foundation and Model 350F uses the existing floor). Find the applicable assembly instructions in **Section 3.2** based on model type.

## 3.2 Installation

**⚠ WARNING** If multiple cranes were ordered, locate stamped serial number on each crane part for proper part matching during installation. Although crane parts may appear to be identical, each crane is assembled and built separately. All parts that do not have the same stamped serial number may not line up properly for installation.

### 3.2.1 Model 350: Light Duty – Base Mounted:

3.2.1..1 Reference the Foundation Drawing and Jib Crane Drawing included in the jib crane information packet.

3.2.1..2 **⚠ WARNING** Consult a qualified structural engineer to determine that your support structure is adequate to support the loads generated by anchor bolt force, overturning moment, or axial load of your crane. Suggested foundation requirements and curing times are recommendations only. Because conditions may vary, consult a qualified professional to verify foundation requirements.

3.2.1..3 **NOTICE** Foundation requirements are based on a soil pressure of 2500 lbs. per square foot. Concrete recommended for jib crane foundation is 3000 lbs. per square inch or compressive force.

3.2.1..4 **NOTICE** Recommended curing time for foundation/concrete before mast installation is 10 days. Recommended curing time for foundation/concrete before loading crane to full capacity is 28 days.

3.2.1..5 Pour foundation with ANCHOR BOLTS located according to base plate bolt pattern (see **Foundation Drawing**).

3.2.1..6 After foundation is properly cured, spread grout over foundation approximately 1" thick & the same diameter as BASE PLATE (or square dimensions for applicable models). See **Foundation Drawing**. Grout must be a non-shrink, high compressive machinery type grout.

3.2.1..7 Lower MAST ASSEMBLY over ANCHOR BOLTS and set on foundation grout surface. Tighten ANCHOR BOLTS until MAST ASSEMBLY is plumb in all directions (see **Figure 3-1**). Grout is soft and will allow BASE PLATE to settle for plumbing procedure.

**⚠ WARNING** Plumbing of mast assembly is very important and will affect performance of jib crane

3.2.1..8 After grout has properly cured, fully tighten ANCHOR BOLTS to manufacturer's specification. Verify that the MAST ASSEMBLY is still plumb.

3.2.1..9 Lubricate TOP PIN on MAST ASSEMBLY and bronze BUSHING with high grade grease and set head assembly over TOP PIN. Make sure BUSHING fits over any imperfections caused by shipping.

3.2.1..10 Proceed to **Section 3.3** to install HEAD and BOOM assembly.

### 3.2.2 Model 350F: Light Duty – “Foundationless”:

3.2.2.1 Reference the Jib Crane Drawing included in the jib crane information packet.

3.2.2.2 **▲WARNING** Consult a qualified structural engineer to determine that your support structure is adequate to support the loads generated by anchor bolt force, overturning moment, or axial load of your crane. Customer is responsible for determining adequacy of the existing concrete floor prior to mounting

3.2.2.3 **▲WARNING** Existing concrete must be a minimum of 6” thick reinforced, 3000 lbs. per square inch, with a soil content of 3,000 lbs. per square foot. Concrete in and around mounting site must be consistent and free of any cracks, joints, seams, walls, or wearing within a 6’ x 6’ area.

3.2.2.4 **▲WARNING** Installer is responsible for providing proper anchors for install based on diameter and jib crane reactions.

3.2.2.5 Install chemical ANCHOR BOLTS with a *minimum* of 4-3/4” embedment (See **Figure 3-2**). ANCHOR BOLT must have a minimum of two threads above nut after installation

3.2.2.6 Spread mechanical grout over floor approximately 1” thick & the same diameter as BASE PLATE. See Foundation Drawing. Grout must be a non-shrink, high compressive machinery type grout.

3.2.2.7 Lower MAST ASSEMBLY over ANCHOR BOLTS and set on foundation grout surface. Tighten ANCHOR BOLTS until MAST ASSEMBLY is plumb in all directions (see **Figure 3-1**). Grout is soft and will allow BASE PLATE to settle for plumbing procedure.

**▲WARNING** Plumbing of mast assembly is very important and will affect performance of jib crane

3.2.2.8 After grout has properly cured, fully tighten ANCHOR BOLTS to manufacturer’s specification. Verify that the MAST ASSEMBLY is still plumb.

3.2.2.9 Proceed to **Section 3.3** “Head and Boom Installation”

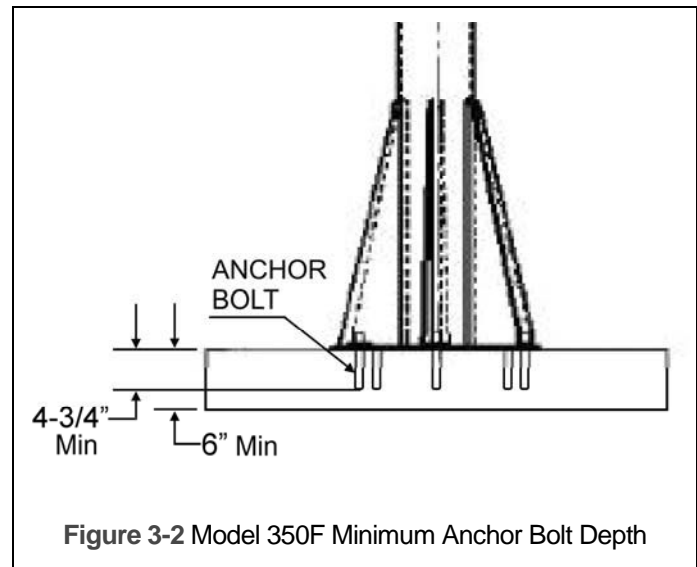
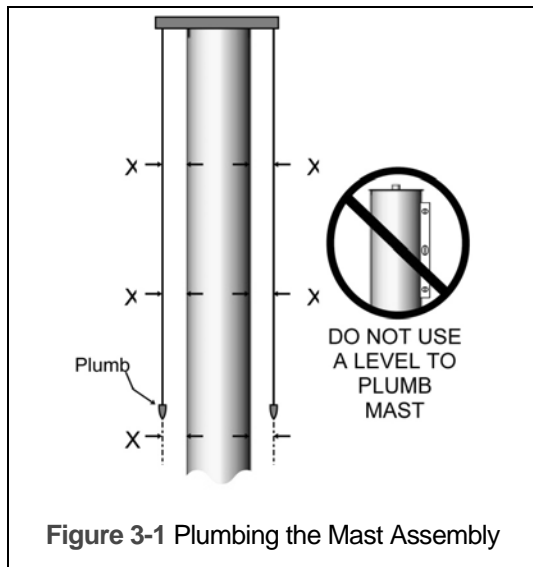

### 3.3 Head and Boom Assembly

- 3.3.1 Reference **Figure 3-3** for general assembly layout.
- 3.3.2 After grout has hardened, lubricate TOP PIN on MAST ASSEMBLY and bronze BUSING with high grade grease and set HEAD ASSEMBLY over TOP PIN. Make sure BUSHING fits over any imperfections caused by shipping.
- 3.3.3 The ROLLER GUARD is shipped loose, so remove lock washers and nuts, add the ROLLER GUARD to the ROLLER, and reinstall lock washers and nuts.
- 3.3.4 Bolt the BOOM ASSEMBLY to the HEAD ASSEMBLY.
- 3.3.5 If applicable, install MECHANICAL ROTATION STOPS – See **Section 3.4**.
- 3.3.6 Bolt two INNER END STOPS to BOOM. Slide hoist onto BOOM then bolt two remaining OUTER END STOPS to boom. (For units with Tight Wire Kits, please refer to **Section 3.5** Tight Wire Kit Installation page).
- 3.3.7 Rotate BOOM slowly and check around 360° for binds or slow down spots. Remove interference if any.
- 3.3.8 Tighten all bolts to specified torque (see **Table 3-1**) and unit should be ready for operation.

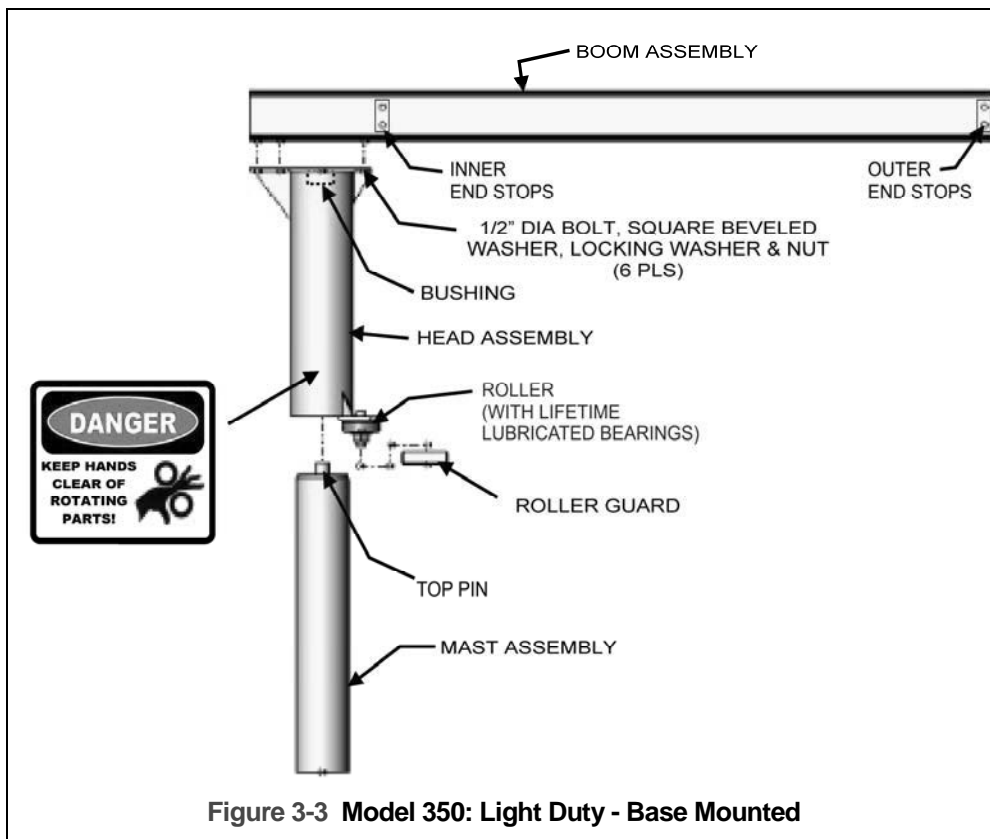

Table 3-1 Torque Specifications	
BOLT DIA.	TORQUE
1/4" - 20	6 ft.-lbs.
3/8" - 16	20 ft.-lbs.
1/2" - 13	50 ft.-lbs.
5/8" - 11	95 ft.-lbs.
3/4"-10	175 ft.-lbs.
7/8" - 9	300 ft.-lbs.

### 3.4 Mechanical Rotation Stops

62898

ITEM NO.	PART NUMBER	MAST DIA	DESCRIPTION	QTY.
1	6289801	5 9/16"	ROTATION STOP KIT	1
2	6289802	8 5/8", 10 3/4"	ANGLE 2" X 2" X 1/4" X 10" L	1
3	TT9003501	5 9/16"	SQUARE BAR 1" X 2" L	2
	TT90035002	8 5/8", 10 3/4"	SQUARE BAR 1.5" X 2" L	
4	Not included w/kit			1
5	Not included w/kit			1

**NOTES**

- ITEM 2 WELDED TO HEAD ASSEMBLY (4) BY MANUFACTURER 180° OPPOSITE ROLLER ASSEMBLY.
- ITEM 3 SHIPPED LOOSE FOR FIELD POSITIONING. ITEM 3 TO BE FIELD WELDED TO OUTSIDE DIAMETER OF MAST ASSEMBLY (5).
- USE DIMENSIONS SHOWN AS A REFERENCE TO MAKE SURE THAT ROTATION STOPS DO NOT INTERFERE WITH ROLLER ASSEMBLY DURING CRANE ROTATION.

**TIGER TRACK**

DESCRIPTION: MODEL 350 JIB CRANE ROTATION STOP KIT  
 PART NUMBER: 6289801/6289802 MATERIAL: \_\_\_\_\_  
 DRAWN BY: D. Grujic DATE DRAWN: 06/08/07 DRAWING SIZE: A SHEET NUMBER: 1 SCALE: 1:5  
**TOLERANCES:** DECIMALS (UNLESS OTHERWISE SPECIFIED) TWO PLACE (.00) + / .015 THREE (0.000) +/- .005 ANGLES +/- 30 MINUTES ALL DIMENSIONS ARE IN INCHES UNLESS OTHERWISE SPECIFIED.

### 3.5 Tight Wire Assembly



## 4.0 Operation

### 4.1 Introduction

The suggestions below are not intended to take precedence over existing plant safety rules and regulations or OSHA regulations. It is the responsibility of the owner to make personnel aware of all federal, state and local rules and codes, and to make certain operators are properly trained.

#### **DANGER**

**DO NOT WALK UNDER A SUSPENDED LOAD**  
**KEEP HANDS CLEAR OF ROTATING PARTS**

#### **WARNING**

CRANE OPERATORS SHALL BE REQUIRED TO READ THE OPERATION SECTION OF THIS MANUAL, THE WARNINGS CONTAINED IN THIS MANUAL, INSTRUCTION AND WARNING LABELS ON THE HOIST OR LIFTING SYSTEM, APPLICABLE ANSI AND OSHA SAFETY STANDARDS, AND THE CRANE OPERATOR'S MANUAL PUBLISHED BY THE CRANE MANUFACTURER'S ASSOCIATION OF AMERICA (CMAA). THE OPERATOR SHALL ALSO BE REQUIRED TO BE FAMILIAR WITH THE CRANE AND CRANE CONTROLS BEFORE BEING AUTHORIZED TO OPERATE THE CRANE OR LIFTING SYSTEM.

CRANE OPERATORS SHOULD BE TRAINED IN PROPER RIGGING PROCEDURES FOR THE ATTACHMENT OF LOADS TO THE HOIST HOOK.

CRANE OPERATORS SHOULD BE TRAINED TO BE AWARE OF POTENTIAL MALFUNCTIONS OF THE EQUIPMENT THAT REQUIRE ADJUSTMENT OR REPAIR, AND TO BE INSTRUCTED TO STOP OPERATION IF SUCH MALFUNCTIONS OCCUR, AND TO IMMEDIATELY ADVISE THEIR SUPERVISOR SO CORRECTIVE ACTION CAN BE TAKEN.

CRANE OPERATORS SHOULD HAVE NORMAL DEPTH PERCEPTION, FIELD OF VISION, REACTION TIME, MANUAL DEXTERITY, HEARING, AND COORDINATION.

CRANE OPERATORS SHOULD **NOT** HAVE A HISTORY OF OR BE PRONE TO SEIZURES, LOSS OF PHYSICAL CONTROL, PHYSICAL DEFECTS, OR EMOTIONAL INSTABILITY THAT COULD RESULT IN ACTIONS OF THE OPERATOR BEING A HAZARD TO THE OPERATOR OR TO OTHERS.

CRANE OPERATORS SHOULD **NOT** OPERATE A CRANE OR LIFTING SYSTEM WHEN UNDER THE INFLUENCE OF ALCOHOL, DRUGS, OR MEDICATION.

#### **NOTICE**

- Read OSHA Specification 1910.179 "Overhead and Gantry Cranes," ANSI B30.11, "Monorails and Underhung Cranes," ASME B30.16, and any other applicable standards.
- Read the hoist manufacturer's Operating and Maintenance Instructions.
- Read all labels attached to equipment.

## 4.2 Shall's and Shall Not's for Operation

### **WARNING**

Improper operation of a crane can create a potentially hazardous situation which, if not avoided, could result in death or serious injury, and substantial property damage. To avoid such a potentially hazardous situation **THE OPERATOR SHALL:**

- **NOT** operate a damaged, malfunctioning or unusually performing crane.
- **NOT** operate a crane until you have thoroughly read and understood Manufacturer's Operating and Maintenance Instructions or Manuals.
- Be familiar with operating controls, procedures, and warnings.
- **NOT** operate a crane that has been modified without the manufacturer's approval.
- **NOT** lift more than rated load for the crane/hoist/trolley.
- **NOT** use the crane to lift, support, or transport people.
- **NOT** lift loads over people.
- **NOT** operate a crane unless all persons are and remain clear of the supported load.
- **NOT** operate unless load is centered under hoist.
- **NOT** leave load supported by the crane/hoist unattended unless specific precautions have been taken.
- **NOT** allow the crane to be used as an electrical or welding ground.
- **NOT** remove or obscure the warnings on the crane.
- **NOT** operate a crane on which the safety placards or decals are missing or illegible.
- **NOT** operate a crane that has any changes in rolling effort or unusual noises.
- Warn personnel before lifting or moving a load.
- Warn personnel of an approaching load.
- Ensure that endstops are in place.
- Ensure that all bolts are tight and have lockwashers.
- **NOT** put hands near rotating parts.

### **CAUTION**

Improper operation of a crane can create a potentially hazardous situation which, if not avoided, could result in minor or moderate injury, or property damage. To avoid such a potentially hazardous situation **THE OPERATOR SHALL:**

- Maintain a firm footing or be otherwise secured when operating the crane.
- Make sure the load is free to move and will clear all obstructions.
- Avoid swinging the load or hook.
- Inspect the crane regularly, replace damaged or worn parts, and keep appropriate records of maintenance.
- Use the crane manufacturer's recommended parts when repairing the unit.
- Lubricate the roller bearings per crane manufacturer's recommendations.
- **NOT** allow your attention to be diverted from operating the crane.
- **NOT** allow the crane to be subjected to sharp contact with other cranes, structures, or objects through misuse.
- **NOT** adjust or repair the crane unless qualified to perform such adjustments or repairs.
- Ensure that festooning cannot be snagged or pinched.



### **4.3 Jib Boom Operation**

4.3.1 Verify the hook is high enough to clear any obstruction before using the boom of the jib crane.

4.3.2 Ensure the jib boom is directly over the load before lifting the load.

4.3.3 Start moving the jib boom slowly and bring it up to speed gradually.

4.3.4 Reduce the speed of the boom as it approaches the place where it should stop.

### **4.4 Trolley Operation**

Refer to the trolley's operating instructions.

### **4.5 Hoist Operation**

Refer to the hoist's operating instructions.

## 5.0 Inspection

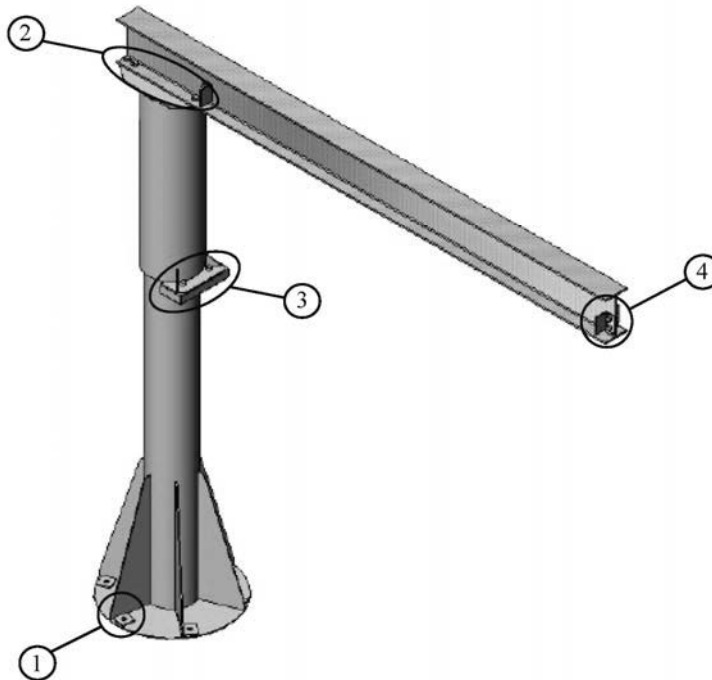

**Table 5-1 Crane Inspection**

Figure No.	Item	Inspection	Frequency	
1	Anchor Bolts	Check that the lock-washers are fully compressed and the nuts are tightened to manufacturer's specifications.	350	Every 500 hours Or 3 months
	Chemical Anchor Bolts		350F	Once per month
2	Boom Hardware	Check that the lock-washers are fully compressed and the nuts are tightened the proper torque specs (see <b>Figure 3-1</b> page).	Every 500 hours Or 3 months	
3	SQ. Bore Bearings	Make sure both roller bearings are evenly touching the mast, adjust if needed. Grease if needed.	Every 1000 hours Or 6 months	
4	End Stop/ Tight Wire Kit	Check that the lock-washers are fully compressed and the nuts are tightened the proper torque specs (see <b>Figure 3-1</b> page).	Every 500 hours Or 3 months	
-	Additional Items	Conduct a general inspection of all additional items you may have purchased.	Every 1000 hours Or 6 months	
-	General	Conduct a visual inspection of the crane overall and speak with the crane operator about the cranes performance, if any flaws are noticed take crane out of service and report to manufacturer immediately.	Every 1000 hours Or 6 months	

### **⚠ WARNING**

Any changes in rolling effort or unusual noises must be immediately identified and corrected.

## 6.0 Lubrication

- 6.1** The most economical way to maintain a jib crane and keep it in good operating condition is to lubricate all moving parts regularly.
- 6.2** Regular inspection of all parts should be made and all loose parts should be adjusted. Parts that become worn should be replaced at once.
- 6.3** The interval of lubrication varies as to the use of the machine. A crane operating 24 hours a day, 7 days a week, should demand lubrication once a week. Whereas a standard duty crane, operating eight hours a day on a five day week should be lubricated once every two to three weeks. Cranes under a standby classification, being used once or twice a month, should be lubricated at least once every six months.
- 6.4** The actual interval from one lubrication to the next depends entirely upon the type and length of operation to which the crane is subjected. This, of course, is variable and sometimes cannot be definitely determined. In this case, the crane operator or maintenance engineer would determine when the crane should be lubricated.
- 6.5** The roller bearings on the jib crane require lubrication. They are serviced by pressure type fittings.
- 6.6** The recommended lubricants for these bearings are:
  - Texaco Marfax No. 0 for below 32 degrees F
  - Texaco Marfax No. 1 for above 32 degrees F
- 6.7** If Texaco products are not available, equivalent lubricants are satisfactory.

## 7.0 Troubleshooting

**Table 7-1 Troubleshooting Guide**

<b>Symptom</b>	<b>Cause</b>	<b>Remedy</b>
Jib crane does not rotate smoothly	Mast pin is not inserted into the bearing housing in the head assembly	Properly insert mast pin into the bearing housing
Does not rotate a complete rotation	Crane boom has an obstruction	Remove any obstruction
	Mast pin is not inserted into the bearing housing in the head assembly	Properly insert mast pin into the bearing housing

## 8.0 Warranty

All products sold by Harrington Hoists, Inc. are warranted to be free from defects in material and workmanship from date of shipment by Harrington for the following periods:

- 1 year – Electric and Air Powered Hoists (excluding (N)ER2 Enhanced Features Models), Powered Trolleys, Powered Tiger Track Jibs and Gantries, Crane Components, Below the Hook Devices, Spare / Replacement Parts**
- 2 years – Manual Hoists & Trolleys, Beam Clamps**
- 3 years – (N)ER2 Enhanced Features Model Hoists**
- 5 years – Manual Tiger Track Jibs and Gantries, TNER Pull - Rotor Motor Brake**
- 10 years – (N)ER2 “The Guardian” Smart Brake**

The product must be used in accordance with manufacturer’s recommendations and must not have been subject to abuse, lack of maintenance, misuse, negligence, or unauthorized repairs or alterations.

Should any defect in material or workmanship occur during the above time period in any product, as determined by Harrington Hoist’s inspection of the product, Harrington Hoists, Inc. agrees, at its discretion, either to replace (not including installation) or repair the part or product free of charge and deliver said item F.O.B. Harrington Hoists, Inc. place of business to customer.

Customer must obtain a Return Goods Authorization as directed by Harrington or Harrington’s published repair center prior to shipping product for warranty evaluation. An explanation of the complaint must accompany the product. Product must be returned freight prepaid. Upon repair, the product will be covered for the remainder of the original warranty period. Replacement parts installed after the original warranty period will only be eligible for replacement (not including installation) for a period of one year from the installation date. If it is determined there is no defect, or that the defect resulted from causes not within the scope of Harrington’s warranty, the customer will be responsible for the costs of returning the product.

Harrington Hoists, Inc. disclaims any and all other warranties of any kind expressed or implied as to the product’s merchantability or fitness for a particular application. Harrington will not be liable for death, injuries to persons or property or for incidental, contingent, special or consequential damages, loss or expense arising in connection with the use or inability whatever, regardless of whether damage, loss or expense results from any act or failure to act by Harrington, whether negligent or willful, or from any other reason.

**This Page Intentionally Left Blank**

## 9.0 Parts Information

When ordering Parts, please provide the crane serial number which is stamped into each crane part (see **Figure 9-1**). The serial number is also located underneath the “Tiger Track” logo.

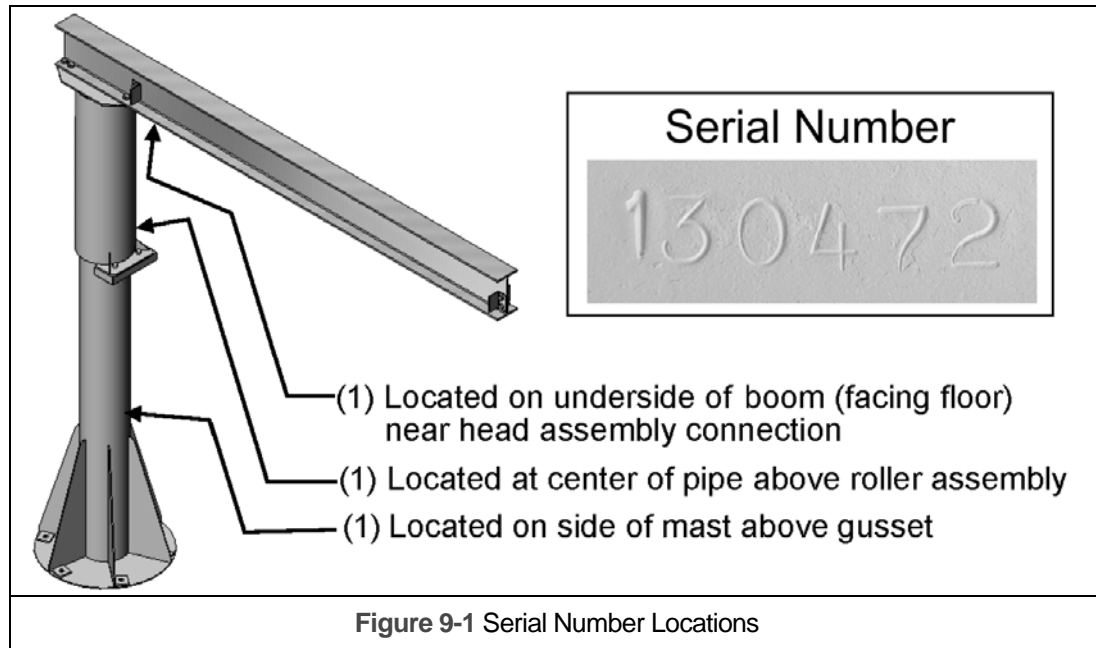

The parts list is arranged into the following sections:

Section	Page
9.1 Jib Crane Parts.....	24
9.2 Roller Cage Assembly Parts.....	26
9.3 Labels.....	28

## 9.1 Jib Crane Parts

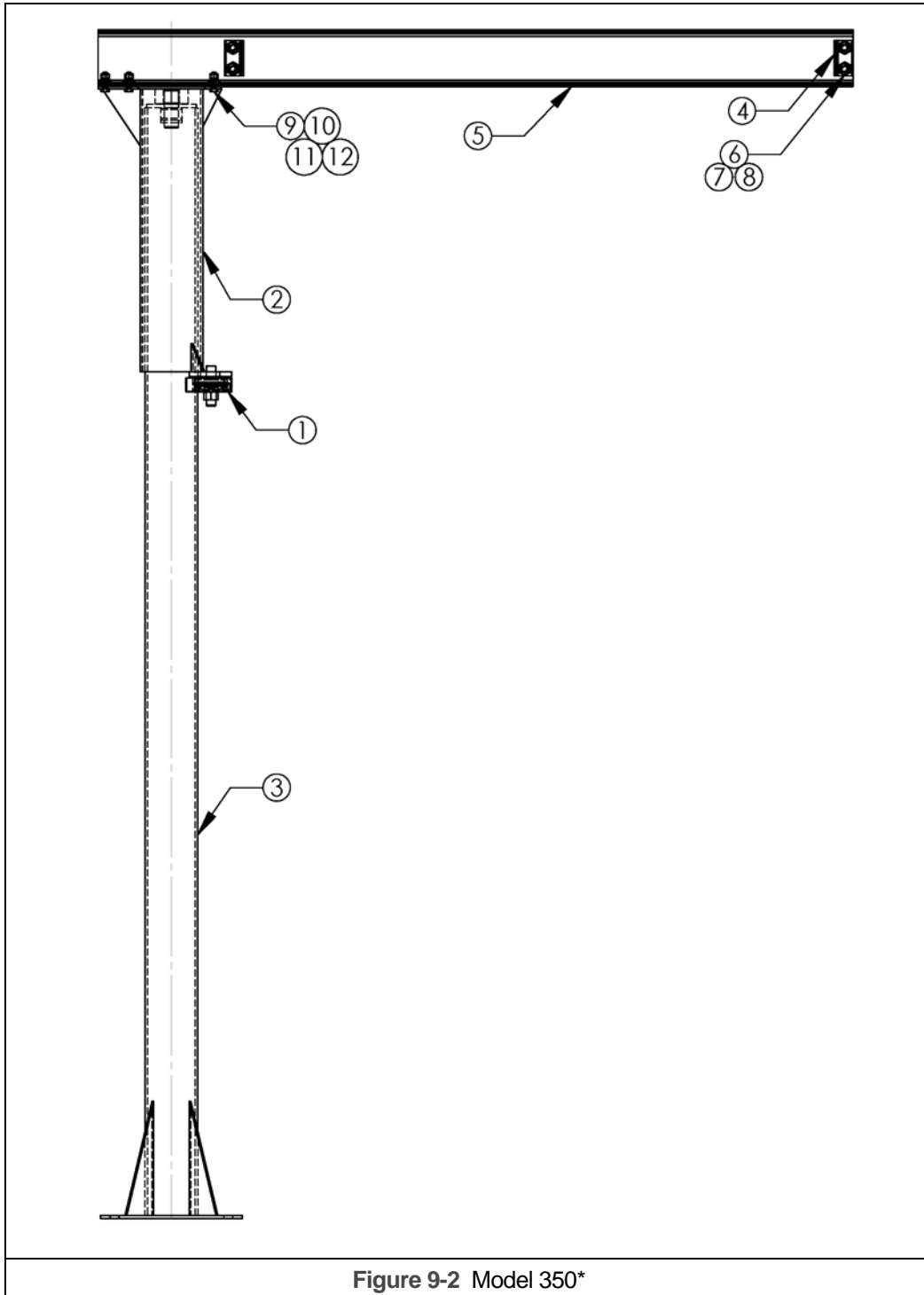

Figure 9-2 Model 350\*

\*Model 350 is shown for reference only, but figure numbers apply for 350F



9.1 Jib Crane Parts

FIGURE NO.	DESCRIPTION	QTY	MAST DIAMETER (inches)		
			5-9/16"	8-5/8"	10-3/4"
1	Roller	2	TT0700211		
2	Head Assembly	1	SEE BILL OF MATERIALS ON JIB CRANE DRAWING		
3	Mast Assembly	1			
4	End Stops	4			
5	Boom Assembly	1			
6	Bolt	4			
7	Lock Washer	4			
8	Nut	4			
9	Bolt	-			
10	Lock Washer	-			
11	Square Beveled Washer	-			
12	Nut	-			

## 9.2 Labels

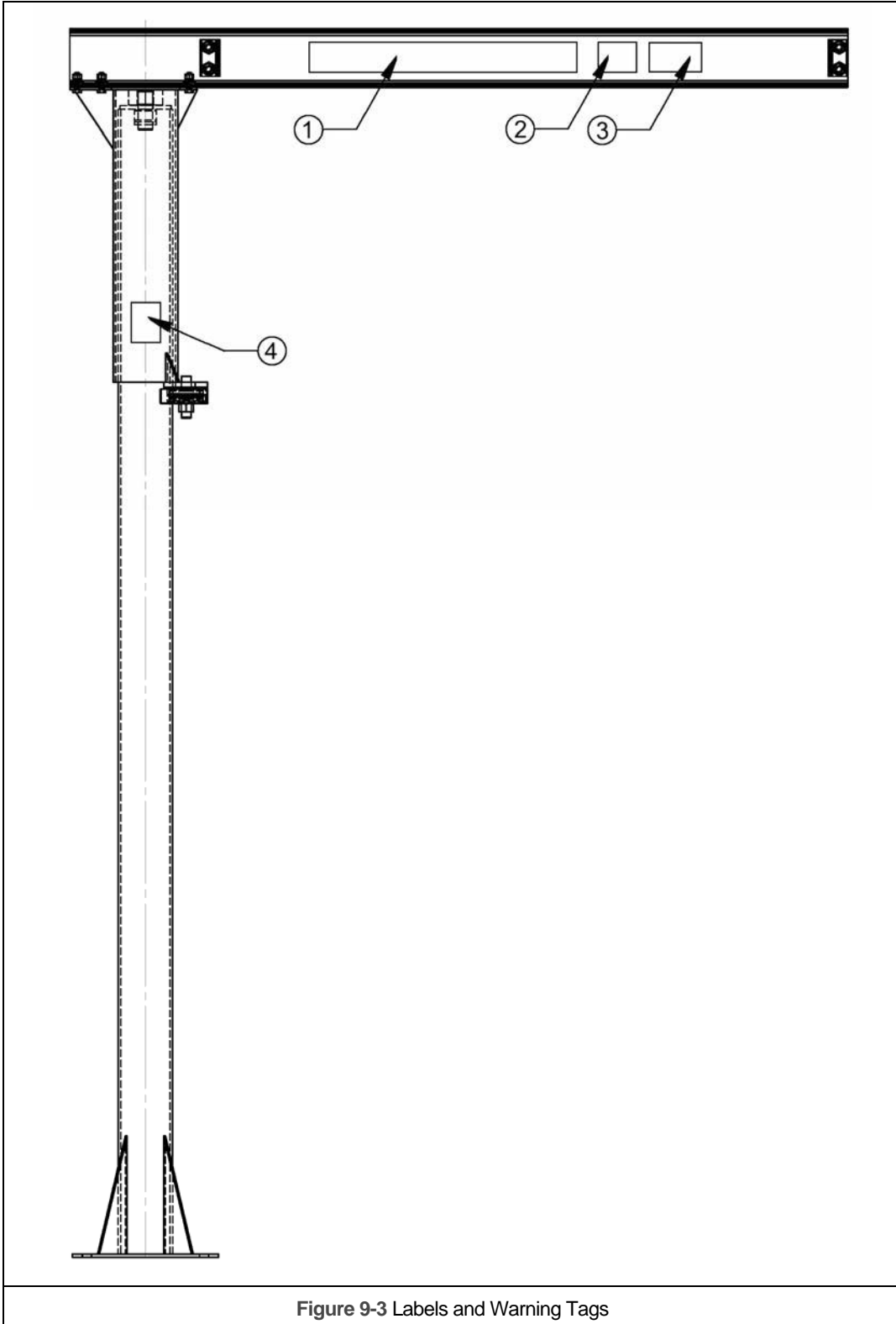

Figure 9-3 Labels and Warning Tags

9.2 Labels

Figure No.	Description	Qty	BOOM HEIGHT   (inches)		
			6	8	10
1	Logo	2	8047301		
2	Capacity Number, 1	-	8047306		
	Capacity Number, 2		8047307		
	Capacity Number, 3		8047308		
	Capacity Number, 4		8047309		
	Capacity Number, 5		8047310		
	Capacity Number, 6		8047311		
	Capacity Number, 7		8047312		
	Capacity Number, 8		8047313		
	Capacity Number, 9		8047314		
	Capacity Number, 0		8047315		
	Capacity Slash		8047316		
3	Capacity Unit, TON	2	8047303		
	Capacity Unit, LBS		8047304		
	Capacity Unit, KG		8047305		
4	Danger label	2	80472		



Harrington Hoists, Inc.  
401 West End Avenue  
Manheim, PA 17545

[www.harringtonhoists.com](http://www.harringtonhoists.com)

Toll Free: 800-233-3010  
Phone: 717-665-2000  
Fax: 717-665-2861

**TT3500M-ENG**